

UL Evaluation Report

UL ER15388-01

Issued: April 1, 2014

Revised: January 28, 2019

Visit UL's Online Certifications Directory: www.ul.com/erdirectory
for current status of Report.

UL Category Code: ULFZ

CSI MasterFormat®

**DIVISION: 23 00 00 – HEATING, VENTILATION, AND
AIR CONDITIONING (HVAC)**

Sub-level 2: 23 30 00 – HVAC Air Distribution

Sub-level 3 23 38 00 – Ventilation Hoods

Sub-level 4: 23 38 13 – Commercial-Kitchen Hoods

Sub-level 5: 23 38 13.13 – Listed Commercial-Kitchen Hoods

COMPANY:

Metal-Fab, Inc.
3025 May Avenue
Wichita, KS 67213
www.metal-fabinc.com
ShaunR@MTLFAB.COM

1. SUBJECT

Factory-built grease duct enclosure systems, Models IPIC-4G (IPIC-4), IPIC-3G (IPIC-3), and IPIC-2G (IPIC-2).

2. SCOPE OF EVALUATION

- 2006, 2009, 2012, 2015, and 2018 *International Mechanical Code*® (IMC)
- 2009, 2012, 2015, and 2018 *International Building Code*® (IBC)
- 2006, 2009, 2012, 2015, and 2018 IAPMO *Uniform Mechanical Code* (IAPMO UMC)
- NFPA 96 Standard for Ventilation Control and Fire Protection of Commercial Cooking Operations, 2014 and 2017 Editions
- ICC-ES Acceptance Criteria for Quality Documentation (AC10), Dated January 2018



The products were evaluated for the following properties:

- Durability (UL 2221)
- Fire resistance (UL 1978)
- Noncombustibility (UL 2221)
- Joint Integrity (UL 2221)
- Surface Burning Characteristics (UL 2221)

3. REFERENCED DOCUMENTS

- UL 2221, Tests of Fire Resistive Grease Duct Enclosure Assemblies
- ANSI/UL 1978, Grease Ducts
- ANSI/UL 2561, 1400 Degree Fahrenheit Factory-Built Chimneys
- ANSI/UL 1479, (ASTM E814), Fire Tests of Through-Penetration Firestops

4. USES

4.1 General

Metal-Fab Fire Resistive Grease Duct Assemblies, Models IPIC-4G, IPIC-3G and IPIC-2G, are self-enclosed, factory-built grease duct systems serving Type I kitchen hoods used in buildings required to be of one- or two-hour fire-resistance rated construction. When installed in accordance with this report, each system is an alternate to the grease ducts described in Section 506.3 of the 2018 IMC, Section 510.4 of the 2018 IAPMO UMC and Section 4.3 of NFPA 96 (2017 Edition). These systems can be used to penetrate fire-resistance-rated concrete floor-ceiling assemblies and can also be used to penetrate fire-resistance-rated concrete walls and fire-resistance-rated gypsum/steel-stud wall assemblies when installed in accordance with Section 6.2 and 6.3 of this report.

The fire-resistance rating for Model IPIC-2G is limited to applications where the grease duct is located within fully enclosed combustible or non-combustible (or fire-rated) construction. Applications include locations within a suspended ceiling cavity or where one or more grease ducts within a vertical shaft require separate isolation within separate fire-rated enclosures.

In kitchen exhaust applications that connect to solid fuel cooking appliances which exceed continuous 500°F exhaust temperatures (for example, coal fired pizza ovens) Metal-Fab Fire Resistive Grease Duct Assemblies, Models IPIC-4G, IPIC-3G and IPIC-2G, are permitted to be used based upon their dual Listing status as a Type-HT residential chimney system for solid fuel heating appliances.

4.2 Duct Slope

The IMC and UMC specify minimum slope angles for horizontal grease ducts greater than 75 feet (23 m) in length. NFPA 96 Section 7.1.4 (2017 Edition) also requires equivalent minimum duct slope values unless a Factory-Built grease duct system has been listed to be installed at a lesser slope. Metal-Fab Fire Resistive Grease Duct Assemblies have been evaluated by UL in accordance with ANSI/UL 1978 to be installed at a minimum $1/16$ -inch vertical per 1-foot horizontal duct slope. For horizontal ducts that exceed 75-feet in length, the minimum duct slope shall be increased to $1/4$ -inch vertical per 1-foot horizontal duct span.

The UL Listing for the reduction in duct slope as permitted by UL 1978 is based upon tests and evaluation that demonstrates equivalent alternate construction to that prescribed in the IMC, UMC and NFPA 96 and as shown in the manufacturers [installation instructions](#) (issued November 2013).

5. PRODUCT DESCRIPTION

5.1 Grease Duct Systems:

Model IPIC grease duct systems are fully assembled at the factory. Construction consists of an inner duct wall (flue) and outer wall (casing) spaced apart with a high density, non-combustible ceramic fiber that completely fills the void within the double wall construction.

The flue is manufactured from a minimum 0.035-inch-thick (0.889 mm), Type 304, 316 or Type 430 stainless steel. The outer casing is manufactured from a minimum 0.024-inch-thick (0.610 mm) aluminized steel or Type 304, Type 316 or Type 430 stainless steel.

For Model IPIC-4G, the annular space between the flue and casing is filled with a high density ceramic fiber blanket for a total thickness of 4 inches. For Model IPIC-3G, the annular space between the flue and casing is filled with a high density ceramic fiber blanket for a total thickness of 3 inches. For Model IPIC-2G, the annular space between the flue and casing is filled with a high density ceramic fiber blanket for a total thickness of 2 inches. The ceramic fiber blanket is non-combustible and has a minimum density and thickness as shown in Table 1.

TABLE 1 – Ceramic Fiber Thickness and Insulation

Model Designation	Thickness (minimum)	Density (minimum)
IPIC-2G	2 in. (5 cm)	6 pcf (96 kg/m ³)
IPIC-3G	3 in. (7.6 cm)	6 pcf (96 kg/m ³)
IPIC-4G	4 in. (10 cm)	6 pcf (96 kg/m ³)

Model IPIC-4G and IPIC-3G duct enclosure systems are available with inside diameters of 6 inches (152 mm) through 36 inches (914 mm), in 2-inch (51 mm) increments. The Model IPIC-2G is available with inside diameters of 6 inches (152 mm) through 18 inches (457 mm) in 2-inch (51 mm) increments. Each system comes in standard duct lengths of 9, 18, 30 or 42 inches (229, 457, 762 or 1067 mm). Other components include duct supports, expansion joints, grease manifold tees, access covers, fan adaptor plates, and tee caps.

5.2 Expansion Joints:

Expansion joints, which are used to accommodate thermal expansion and for making up odd lengths, are made of materials identical to those of the grease duct system. The joint is comprised of a 5-¹/₄-inch-long (133 mm) collar, a 30-inch-long (762 mm) flanged tube with a diameter equal to the inner diameter of the installed duct system, and a 36-inch-long (914 mm) outer jacket. The final assembled length of the expansion joint is determined upon installation and ceramic fiber blanket is applied during the installation. The outer casing is then installed and trimmed to length if necessary. Ceramic fiber (provided by the manufacturer) is the same density and thickness to that of the duct system installed.

5.3 Ceramic Insulation:

Ceramic insulation is supplied by Metal-Fab, Inc., and is installed at the jobsite for duct joints and through penetration firestops. For duct joints, insulation thicknesses and densities are as shown in Table 1. Insulation rolls are cut to proper width for duct joints and are to be solidly packed within a joint prior to installing the outer casing band to secure the insulation.

5.4 Sealant:

Two layers of sealant are applied at each joint in a duct system. The joint system has been evaluated to the requirements of UL 1978 to prevent leakage under fire conditions for the joint system tested. The sealant is provided by Metal-Fab, Inc. and is labeled P080.

5.5 Fan Adaptor Plate:

Fan Adaptor Plates are provided as an engineered method to terminate the grease duct system to a roof curb that is typically used to support an exhaust fan. For Model IPIC-4G and IPIC-3G, the duct enclosure system that is located within the roof curb can maintain a minimum zero clearance to the inner wall of the roof curb. See Fig. 1A, 1B, and 1C. For Model IPIC-2G, minimum clearance to the inner wall of the roof curb shall vary depending on combustibility of the roof curb. See product marking for proper clearances.

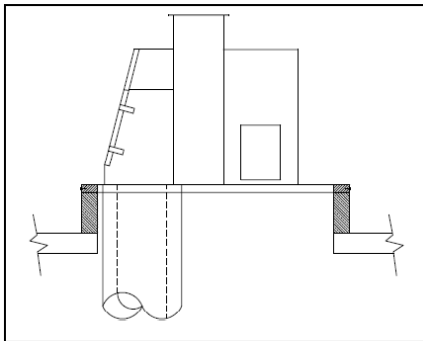

Fig. 1A - Utility Fan Curb / Duct

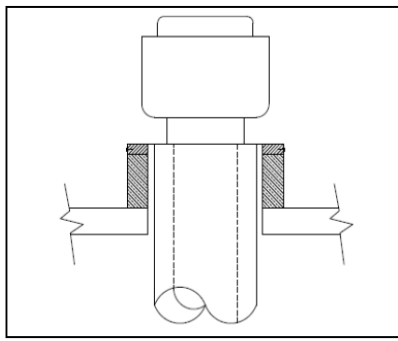

Fig. 1B - Up blast Fan Curb / Duct

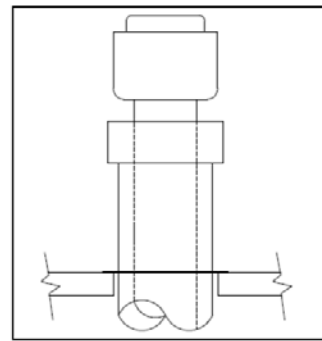

Fig. 1C - Fan Curb Termination

5.6 Access Panels:

Access Panels, which are used to provide access to the inner duct for inspection and maintenance, are installed in accordance with 2018 IMC Section 506.3.12, and are provided by Metal-Fab in two styles. Side Access Panels, noted as Model IPIC-STAP are provided by Metal-Fab, Inc. as part of a fully assembled duct section where by the access panel is located on the side wall of the duct enclosure system. The IPIC-STAP assembly includes a tool-less accessible inner duct access panel, a pillow block of high density insulation and an outer casing panel. See Fig. 2A.

Metal-Fab, Inc. also provides a means of access where ducts change in direction. This type of access panel is located at the end or tap of a TEE section and is noted as Models IPIC-2, -3, or -4 -TAP (Tool-less Access Panel). The IPIC-TAP is constructed of the same flue material, casing material and insulating material as used on the grease duct system. See Fig. 2B.

When installing access panels, room shall be provided to allow physical access to remove and reinstall the access panels. The panel shall be marked with the wording, "ACCESS PANEL. DO NOT OBSTRUCT."

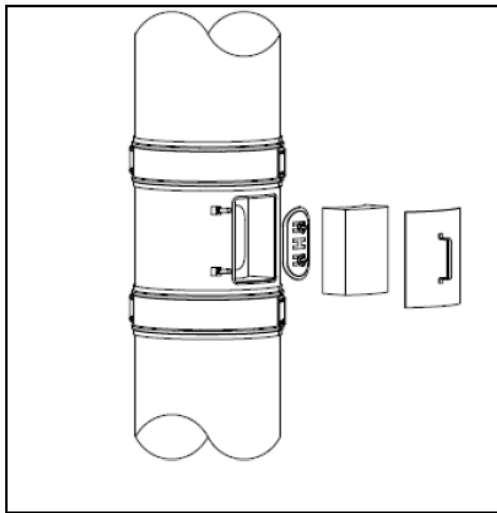

Fig. 2A – Sidewall Tooless Access Panel

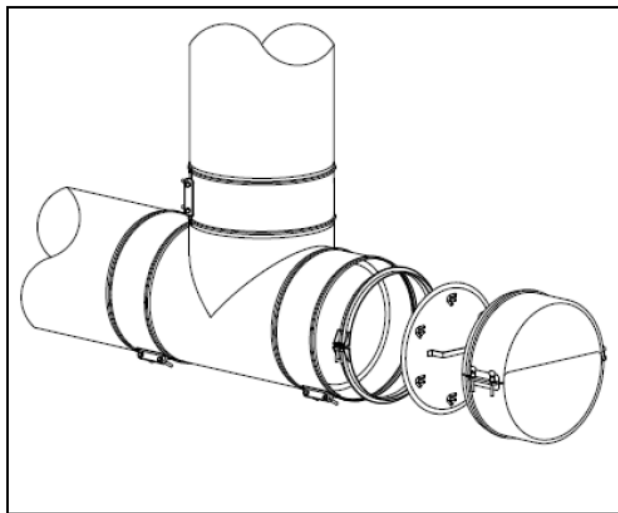

Fig. 2B – Tooless Access Panel

5.7 Transition Section:

Metal-Fab transition sections are provided by the manufacturer to allow Models IPIC-3G and IPIC-4G grease duct enclosure systems to be connected (via continuous joint weld) to field fabricated grease ducts that comply with minimum material and fabrication requirements per the IMC and NFPA 96. The inner duct of the transition section is fabricated of 300 or 400 series stainless steel with a minimum 0.043 inch (1.1 mm) thickness (18 ga). The inner duct shall be connected to field fabricated grease duct of similar shape using a joint welding methods as prescribed in Section 506.3.2 of the 2018 IMC. The joint is then insulated per the manufacturer's instructions with a final layer of insulation overlapping the joint by a minimum of 6 inches (152 mm). See Figure 3A (Transition from Kitchen Exhaust Hood) and Figure 3B (Transition to field fabricated duct and fire rated enclosure system).

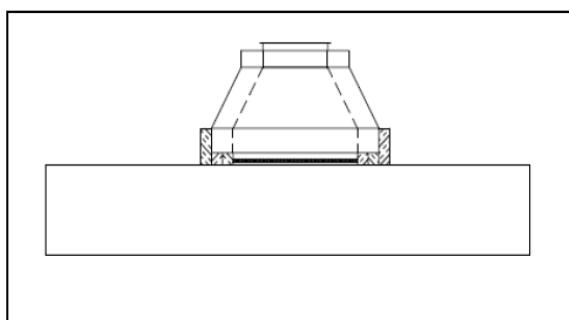

Fig. 3A – Duct transition from exhaust hood

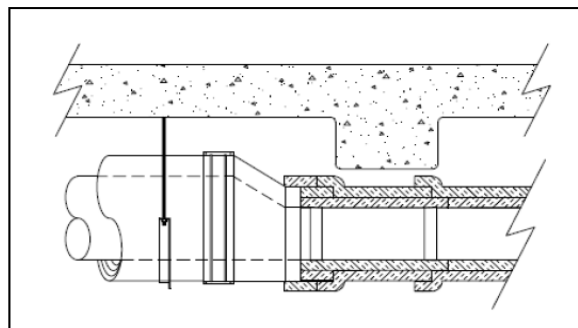

Fig. 3B – Transition to welded duct w/duct wrap

The transition is suitable for applications where the Model IPIC-3G and IPIC-4G encounter interference fit due to building structures. It is also applicable where carbon steel field-fabricated grease ducts have deteriorated due to corrosion and require partial replacement of more corrosion resistant grease duct which listed factory-built grease duct provides.

6. INSTALLATION

6.1 General

The manufacturers published installation instructions and this report must be strictly adhered to, and a copy of the instructions must be available at all times on the jobsite during installation.

The grease duct system must be installed in accordance with 2018 IMC Section 506.3 and 2018 IAPMO UMC Section 510, with the manufacturer's instructions and this report.

Duct sections are connected by mechanical joints consisting of integral flanges on adjoining inner wall sections, held together with a 0.024-inch-thick (0.610 mm) stainless steel flange band and sealed with Type P080 sealant. Next, a strip of noncombustible, ceramic fiber insulation that is 1-inch-thick (25 mm) and a nominal 6-inches (152 mm) wide, is placed around the joint of the inner wall sections in layers in a manner that the insulation is tightly packed and completely fills the void in the joint area. For Model IPIC-4G, a minimum of 4 layers of insulation is used to fill the void. For Model IPIC-3G, a minimum of 3 layers is used to fill the void. For model IPIC-2G, a minimum of 2 layers is used to fill the void. Once the strip of insulation is installed, the outer casing sections are then joined with a closure band. See Fig. 4 for typical connection details.

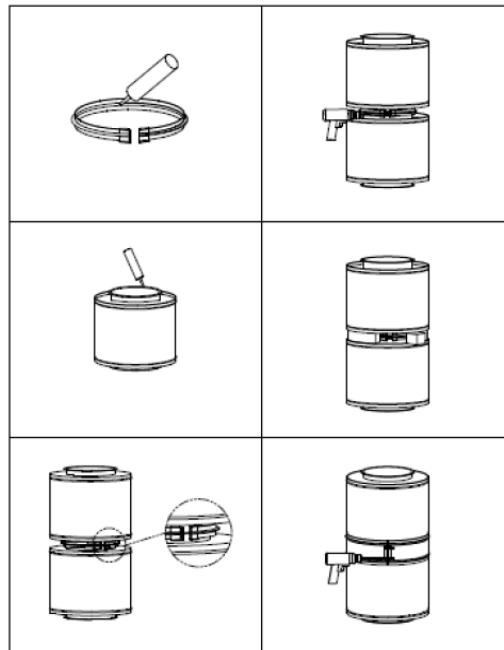

Fig. 4 – Duct Joint Connection

Expansion joints are assembled in accordance with the manufacturer's installation instructions. Expansion joints are located between fixed supports to allow for thermal expansion. The expansion joint is not suitable for use to correct misalignment.

Access to the interior of the duct must be provided at the duct entry or discharge and at each floor level in accordance with NFPA 96, and/or 2018 IMC Sections 506.3.8, 506.3.8.1, 506.3.8.2, and 506.3.9, as applicable. A grease duct manifold tee is provided at each floor level and is capped by the following typical connection details, using a tee cap with a closure band (identified as part IPIC-TAP or IPIC-TCN).

Another method to provide access at each floor is with the sidewall access panel (Model IPIC-STAP). See Figures 5A and 5B.

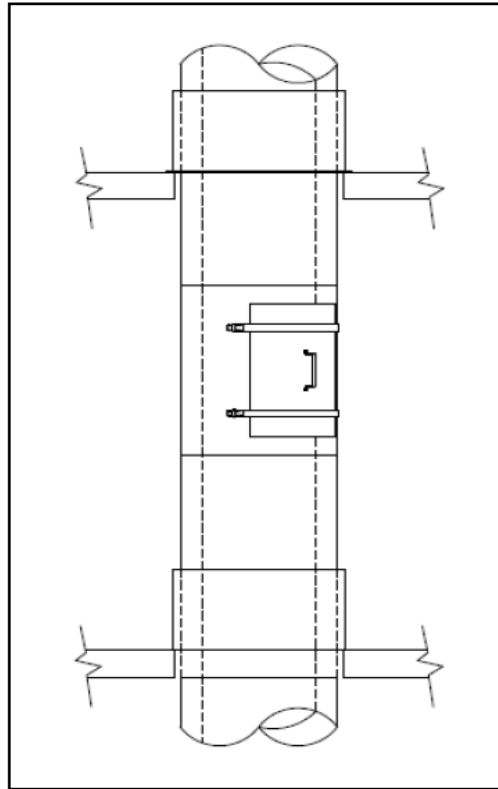
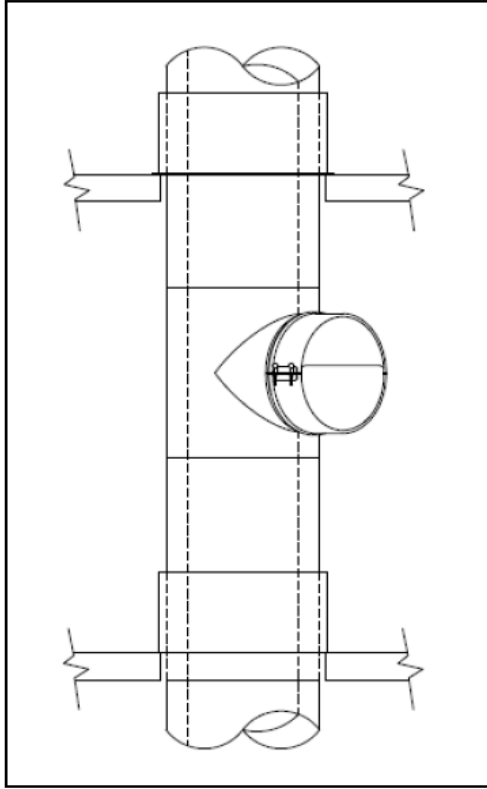

Fig. 5A - Access between floors (PIC-TAP shown) Fig. 5B - Access between floors (PIC-STAP shown)

Models IPIC-4G and IPIC-3G may be installed with zero clearance between the outer casing and combustible construction. Model IPIC-2G must maintain a minimum 3-inch (76 mm) air space between the outer casing and nearby combustibles when installed in fully enclosed construction. An example of such construction includes architectural fascia that conceals the duct enclosure system between a floor and ceiling. See Fig. 6. Another example would be locating the duct enclosure above a suspended ceiling where the duct is hidden from view. See Fig. 7.

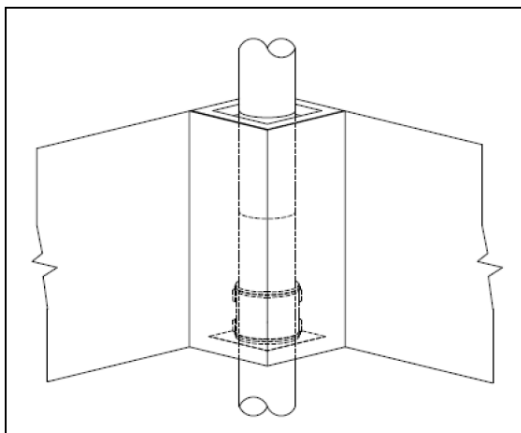

Fig. 6 – Combustible enclosure with IPIC-2G

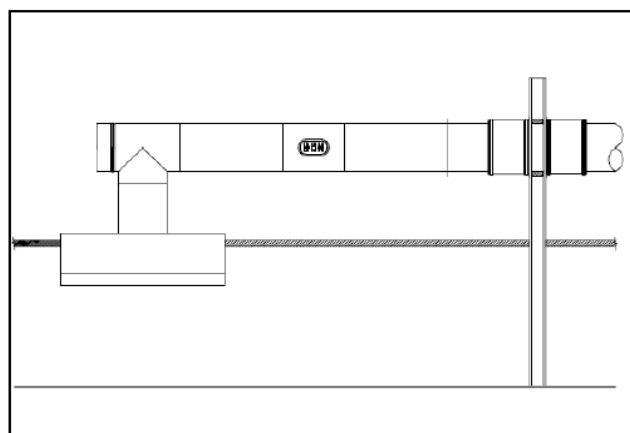

Fig. 7 – IPIC-2G concealed above ceiling is 2-hr. rated

Codes require that a duct enclosure shall only serve a single grease duct and shall not contain other ducts, piping, or wiring systems. For applications that require multiple grease ducts located in one shaft, each grease duct shall be separated by a fire rated enclosure. The integral fire rated enclosures for Model IPIC-4G, IPIC-3G and IPIC-2G are designed to meet this requirement. See Fig. 8.

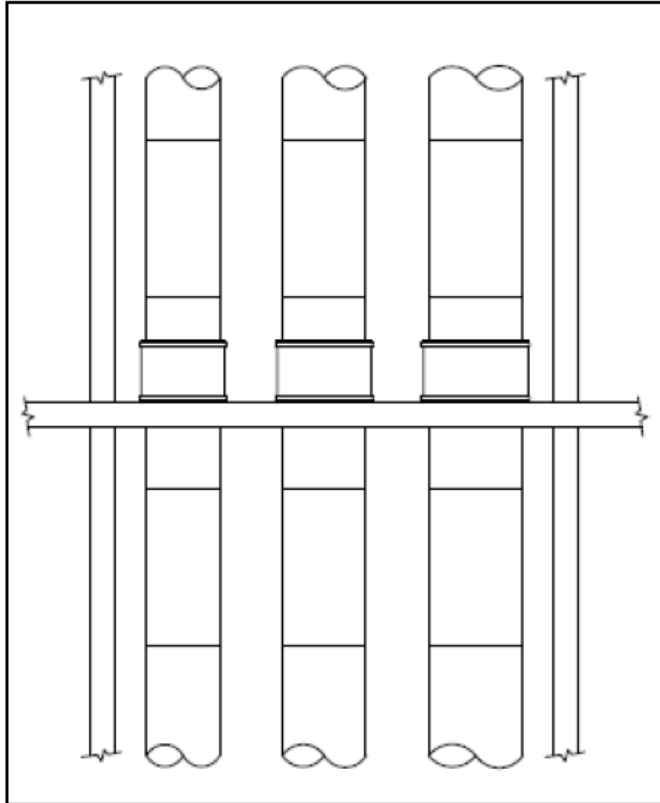

Fig. 8 – Multiple rated grease ducts located in single shaft

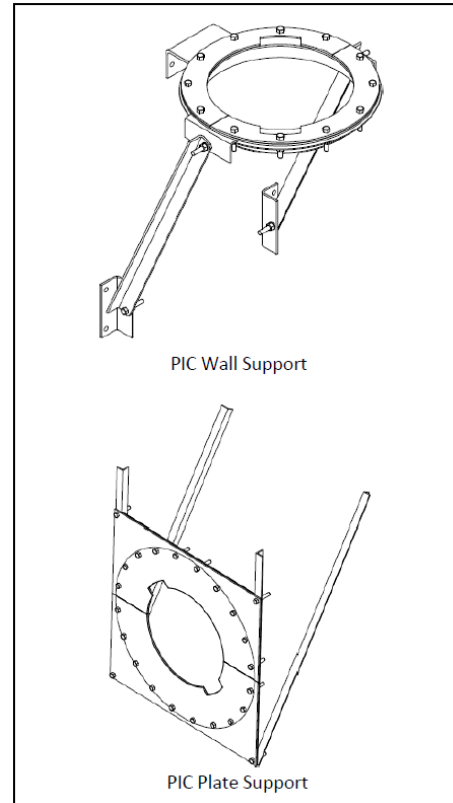

Fig. 9 – Mfr. supplied duct supports

The duct enclosure system is supported with support mechanisms provided by the manufacturer, as illustrated in Fig. 9. Maximum unsupported spacing is 13 feet (4 m) vertically and 9 feet (2.7 m) horizontally.

6.2 Through-Penetration Fire-Stop Systems (Concrete Wall and Floor/Ceiling):

Penetrations by the duct through minimum 4½-inch-thick (114 mm) concrete floor-ceiling assemblies complying with 2018 IBC Table 721.1(3), or minimum 4½-inch-thick (114 mm) wall assemblies complying with 2018 IBC Table 721.1(2), must be protected as follows: The maximum 1-inch (25.4 mm) annular space is filled with bulk ceramic insulation with a minimum 6-pcf (136 kg/m³) density, to within ½ inch (12.7 mm) of the upper and lower surfaces. The remaining space is filled with 3M CP 25WB+ caulk supplied (Fig. 10A) by Metal-Fab, Inc. (or FS-ONE caulk manufactured by Hilti, Inc.), which is sloped at a height of 1⅞ inches (28.6 mm) against the duct (angle of slope is 50° nom.) On the upper surface of the assembly (floor) a two-piece, 0.035-inch-thick (0.889 mm), Type 304 stainless steel plate, cut to the appropriate duct size, is placed around the duct and mechanically attached to the floor. One-inch-thick by 12-inch-wide (25.4 mm by 305 mm) ceramic fiber insulation, minimum 6 pcf (136 kg/m³) density, is then wrapped around the duct and secured with an outer layer of 0.035-inch-thick (0.889 mm), Type 304 stainless steel. The floor-ceiling assembly as described has F- and T- ratings of three hours. Wall assemblies follow the same installation method, however a stainless steel plate is applied to both sides of

an interior wall and insulation is installed and secured with secured with a stainless steel jacket as previously described to provide a symmetrical F- and T- rating for both directions of the wall. A finished view of the ceiling penetration is shown in Figure 10B. Penetrating items include Model IPIC-4G, IPIC-3G and IPIC-2G. Refer to UL's Online Certifications Directory for details of Through-penetration Firestop System [C-AJ-7006](#).

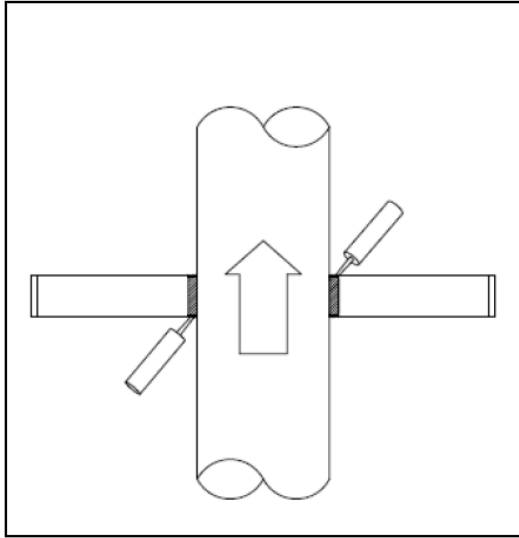

Fig. 10A – Through-penetration fill and caulk

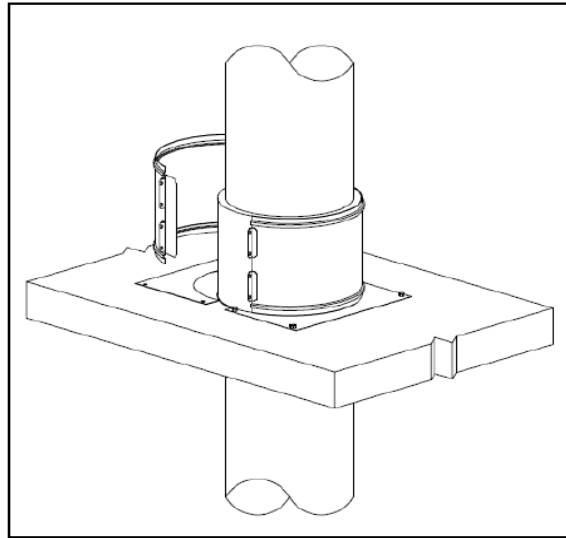

Fig. 10B – Through-penetration plate/collar for T-rating.

6.3 Through-Penetration Fire-Stop Systems (Gypsum/Steel Stud Wall):

Penetrations by the duct through gypsum finished wall assemblies complying with 2018 IBC Table 721.1(2) must be protected as follows: Cut a round hole in the gypsum faced wall approximately 1½ inches larger than the outer diameter of the penetrating duct. Before installing the duct, verify the studs within the wall are steel. The square metal frame shall completely encircle the penetrating duct. Wrap the penetrating duct to fill the ¾-inch annular space with ceramic fiber insulation, minimum 6 pcf (136 kg/m³) density to within ½ inch (12.7 mm) of the both wall surfaces. Means (such as aluminum tape, metal strapping, and metal banding) shall be taken to secure the insulation around the duct casing in situations where the insulation may float freely within the wall cavity. Then apply a minimum 5/8-inch (16 mm) thickness of fill material labeled Hilti, Inc. FS-ONE sealant as shown in Fig. 11A. The material is to be applied within the annulus, flush to both surfaces of the wall. The fill material will completely fill the void between cut edge of the gypsum board and the outer casing of the grease duct. One-inch-thick by 12-inch-wide (25.4 mm by 305 mm) ceramic fiber insulation, minimum 6 pcf (136 kg/m³) density, is then wrapped around the duct (on each side of an interior wall) and secured with an outer layer of 0.035-inch-thick (0.889 mm), Type 304 stainless steel. Additional channels and/or steel studs are required within the stud cavity to completely frame out the opening. The wall assembly as described has F- and T- ratings of 1- or 2-hours. A finished view of the wall penetration is shown in Figure 11B. Penetrating items include Model IPIC-4G, IPIC-3G and IPIC-2G. Refer to UL's Online Certifications Directory for details of Through-penetration Firestop System [W-L-7124](#).

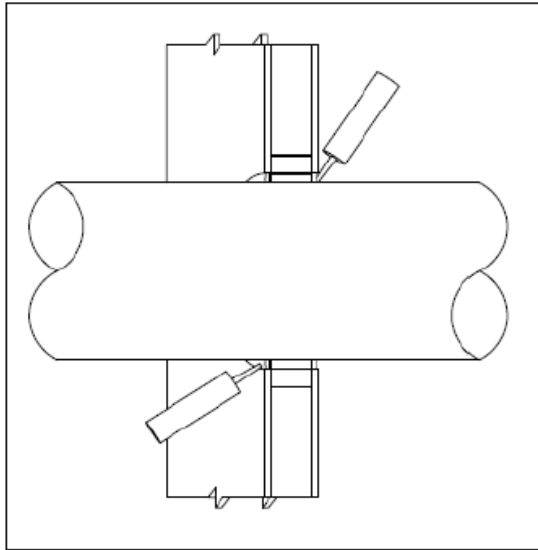

Fig. 11A - Through-penetration fill and caulk

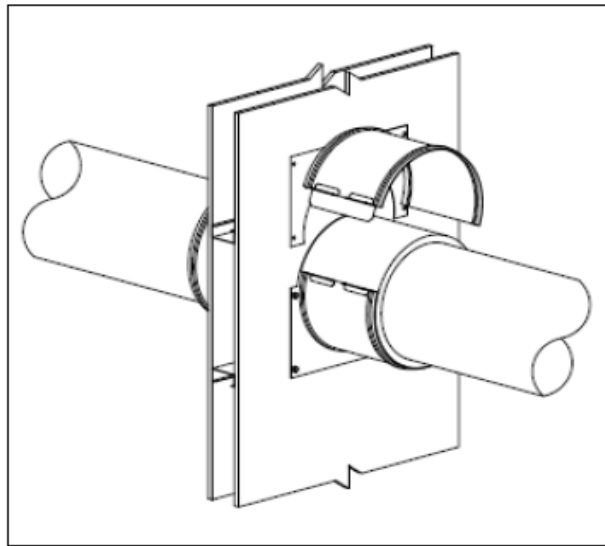

Fig. 11B – Through-penetration plate/collar for T-rating.

7. CONDITIONS OF USE

Models IPIC-4G (IPIC-4), IPIC-3G (IPIC-3), and IPIC-2G (IPIC-2) as described in this report, comply with, or are suitable alternatives to what is specified in, those codes listed in section 2.0 of this report, subject to the following conditions:

- 7.1 The products must be manufactured, identified, and installed in accordance with this report, the manufacturer's published installation instructions, and the applicable code. If there is a conflict between the manufacturers published installation instructions and this report, this report governs.
- 7.2 All assemblies shall be built in accordance with the applicable published UL designs, or as otherwise described within this report.
- 7.3 See UL's Online Certifications Directory for Through-penetrating products ([XHLY](#)), File R15388, evaluated as a part of fire-resistance-rated assemblies in accordance with ANSI/UL 1479 as shown in Table 2.

TABLE 2 – UL 1479 Through-Penetration Firestop Systems

Model (Series) Designation	Nominal Inside Diameter (in.)	Through-penetration Firestop System No.
IPIC Series 4G	28	W-L-7124
IPIC Series 4G	36	C-AJ-7006
IPIC Series 3G	30	W-L-7124
IPIC Series 3G	36	C-AJ-7006
IPIC 2G	18	C-AJ-7006

7.4 See UL's Online Certifications Directory for fire resistive Grease Ducts ([HNOB](#)), File R15388, evaluated in accordance with UL 2221.

IPIC Series 4G (IPIC-4G) Grease Duct for use in Grease Duct Assembly No. [G-1](#). Assembly Classified in accordance with:

- SBCCI Public Safety Testing and Evaluation Services Inc. Evaluation Guide on Fire Resistance Construction (Flexible Duct Wrap Enclosure Systems), dated January 1, 1998, as an alternate to 3 Hr fire rated shaft enclosures with a minimum zero clearance to combustibles, and;
- UL 2221, "Tests of Fire Resistive Duct Enclosure assemblies", as an alternate to 2 Hr fire resistive shaft enclosures with a minimum zero clearance to combustibles. Duct evaluated in accordance with the requirements for duct enclosure Condition A.

IPIC Series 3G (IPIC-3G) Grease Duct for use in Grease Duct Assembly No. [G-1](#). Assembly Classified in accordance with:

- UL 2221, "Tests of Fire Resistive Duct Enclosure assemblies", as an alternate to 2 Hr fire resistive shaft enclosures with a minimum zero clearance to combustibles. Duct evaluated in accordance with the requirements for duct enclosure Condition A.

IPIC Series 2G (IPIC-2G) Grease Duct for use in Grease Duct Assembly No. [G-1](#). Assembly Classified in accordance with:

- UL 2221, "Tests of Fire Resistive Duct Enclosure assemblies", as an alternate to 2 Hr fire resistive shaft enclosures with a minimum 3 in. clearance to combustibles. Duct evaluated in accordance with the requirements for duct enclosure Condition B.

7.5 Models IPIC-4G (IPIC-4), IPIC-3G (IPIC-3), and IPIC-2G (IPIC-2) are manufactured by Metal-Fab, Inc., located at the manufacturing location named below, under the UL LLC Classification and Follow-Up Service Program, which includes inspections in accordance with the quality elements of ICC-ES Acceptance Criteria for Quality Documentation, AC10.

Manufacturing location:

Metal-Fab, Inc.
2013 S. West St.
Wichita, KS 67213

8. SUPPORTING EVIDENCE

- 8.1** Manufacturer's product literature and quality documentation.
- 8.2** UL Classification reports in accordance with UL 2221. See UL Product Certification Category Grease Ducts ([HNOB](#)).
- 8.3** UL Classification reports in accordance with UL 1978. See UL Product Certification Category, Grease Ducts for Restaurant Cooking Appliances ([YYGQ](#)).
- 8.4** UL Classification reports in accordance with UL 1978. See UL Product Certification Category, Hood and Duct Accessories ([YYXS](#)).

- 8.5 UL Classification reports in accordance with UL 2561. See UL Product Certification Category, Chimneys, 1400 Degree Fahrenheit ([DDTZ](#)).
- 8.6 UL Classification reports in accordance with UL 1479. See UL Product Certifications Category, Through-penetrating Products ([XHLY](#)).
- 8.7 Reports in accordance with ASTM E119.
- 8.8 Documentation of quality system elements described in AC10.

9. IDENTIFICATION

Models IPIC-4G (IPIC-4), IPIC-3G (IPIC-3), and IPIC-2G (IPIC-2) as described in this evaluation report, are identified by a marking bearing the report holder's name (Metal-Fab, Inc.), the plant identification, the product designation, the UL Classification Mark, and the evaluation report number UL ER15388-01. The validity of the evaluation report is contingent upon this identification appearing on the product.

10. USE OF UL EVALUATION REPORT

- 10.1 The approval of building products, materials or systems is under the responsibility of the applicable authorities having jurisdiction.
- 10.2 UL Evaluation Reports shall not be used in any manner that implies an endorsement of the product, material or system by UL.
- 10.3 The current status of this report, as well as a complete directory of UL Evaluation Reports may be found at UL.com via our Online Certifications Directory:

www.ul.com/erdirectory

© 2019 UL LLC

This UL Evaluation Report is not an endorsement or recommendation for use of the subject and/or product described herein. This report is not the UL Listing or UL Classification Report that covers the subject product. The subject product's UL Listing or UL Classification is covered under a separate UL Report. UL disclaims all representations and warranties whether express or implied, with respect to this report and the subject or product described herein. Contents of this report may be based on data that has been generated by laboratories other than UL that are accredited as complying with ISO/IEC Standard 17025 by the International Accreditation Service (IAS) or by any other accreditation body that is a signatory to the International Laboratory Accreditation Cooperation (ILAC) Mutual Recognition Arrangement (MRA). The scope of the laboratory's accreditation shall include the specific type of testing covered in the test report. As the accuracy of any non-UL data is the responsibility of the accredited laboratory, UL does not accept responsibility for the accuracy of this data.