



**INSTALLATION AND  
MAINTENANCE  
INSTRUCTIONS**

**PIC  
IPIC**

# MODEL PIC/IPIC

## CHIMNEY AND VENTS



This symbol on the nameplate means this product is listed by Underwriters Laboratories Inc. and by Underwriters Laboratories of Canada

A MAJOR CAUSE OF CHIMNEY RELATED FIRES IS FAILURE TO MAINTAIN REQUIRED CLEARANCES (air spaces) TO COMBUSTIBLE MATERIALS. IT IS OF UTMOST IMPORTANCE THAT CHIMNEY BE INSTALLED ONLY IN ACCORDANCE WITH THESE INSTRUCTIONS.

**IMPORTANT: DO NOT INSTALL CHIMNEY WITHOUT FIRST READING THESE INSTRUCTIONS VERY CAREFULLY.**

Metal-Fab's Model PIC/IPIC Chimney has been fully tested and listed by Underwriters Laboratories, Inc. and Underwriters Laboratories of Canada.

Chimneys installed in accordance with these installation instructions will comply with national safety standards and building codes.

This booklet contains complete information on details concerning dimensions, installation, clearances to combustibles, and use of non-combustible enclosures. For any additional construction information, refer to Model PIC/IPIC Design Manual - L1690.

- **BREECHING APPLICATIONS**
- **BOILER EXHAUST APPLICATIONS**
- **ENGINE/TURBINE EXHAUST APPLICATIONS**

## GENERAL INFORMATION

### LISTINGS

Metal-Fab Model PIC/IPIC Chimney is "listed" by Underwriters Laboratories, Inc (UL File No. MH8251) as "Building Heating Appliance Chimney" for continuous operation at 1000°F and intermittent operation (less than one hour) at 1400°F. For higher temperature applications, it is also "listed" as "1400°F Factory Built Chimney" for continuous operation at 1400°F and intermittent operation at 1800°F. PIC/IPIC Chimney is "listed" by Underwriters Laboratories of Canada (ULC File No. CMH1272) as a continuous operation "760°C Factory-Built Chimney." PIC/IPIC Chimney is "listed" for use at maximum 60-inch water column (2.19 psig) positive internal pressure when installed in accordance with the section "PIPE AND FITTING ASSEMBLY" for 60 in.wc. in these instructions. See **TABLE 1** for clearances. For sizes 6" to 14" diameter: IPIC-2, IPIC-3 and IPIC-4 chimney is "Listed" to UL103-HT for use as a Residential Chimney and is permitted to be installed within fully enclosed combustible construction at 2" min. clearance.

### APPLICATIONS

Model PIC/IPIC building heating appliance chimneys are suitable for use with building heating appliances and other low heat appliances as described in the Chimney Selection Chart of the National Fire Protection Association Standard No. 211, which produce exhaust flue gas at a temperature not exceeding 1000°F continuous. PIC/IPIC Chimneys are also suitable for use as complete exhaust systems for diesel engines and gas turbines. The Model PIC/IPIC product line is listed for higher heat applications where continuous temperatures are not in excess of 1400°F and where the intermittent maximum temperatures are less than 1800°F.

These chimneys are to be installed as required by NFPA for Factory Built Chimneys and Chimney Units. They are not to be enclosed within combustible construction. An interior exhaust system is to be enclosed in a fire resistive shaft of appropriate size and rating where the exhaust system extends through any story of a building above that in which the connected appliance is located. An unenclosed chimney may be placed adjacent to walls of combustible construction at the clearances specified herein. Consult local authorities having jurisdiction.

Model PIC/IPIC chimneys are intended for use as complete systems connecting the appliance, engine or duct to the outdoors, or as appliance connector, flue gas collector and breeching conveying flue gas to a stack built in conformance with NFPA 211, while operating under positive forced draft, negative draft or neutral gravity flow internal pressure conditions.

The Model PIC/IPIC pipe is ideally suited to this application because it is a circular cross section (low friction loss), double-wall insulated, high-strength to weight ratio design using high quality stainless steels.

Complete system size and capacity information can be obtained from the ASHRAE Handbook, Equipment Volume or by contacting Metal-Fab, Inc., PO Box 1138, Wichita, KS 67201.

Refer to Metal-Fab Model PIC/IPIC Design Manual - L1690 for description of all necessary components.

### MULTI-ENGINE EXHAUSTS NOT RECOMMENDED

Where multiple engines are being considered, it is recommended that they not be connected into one common exhaust system. Exhaust gases tend to flow to cooler, non-operating engines, thereby causing formation of condensation. Consult with your engine manufacturer before the installation of multiple engines vented into a common exhaust.

When designing engine exhaust systems:

- Provide correct pipe diameter and keep runs short with the minimum number of turns possible.
- Ensure that exhaust system is properly supported and is isolated from vibration.
- Pay particular attention to thermal expansion and placement of bellows joints.
- Provide proper condensation traps and drains.

### EXPLOSION PROTECTION

The use of PIC/IPIC fittings such as lateral tees, wyes and elbows should be kept to a minimum to reduce back pressure and accumulation of unburned fuels. When a change of direction is required in an engine exhaust system, fittings used for direction change must be reinforced by means of plate support or wall support assemblies to prevent damage if an explosion caused by ignition of unburned fuel should occur. Additionally, the exhaust system should be equipped with a relief valve if possible. For methods of reinforcement and placement of relief valve, see section titled "ENGINE EXHAUST SYSTEM PRECAUTIONS."

### GREASE DUCT APPLICATIONS

Metal-Fab Model PIC/IPIC chimney is listed as grease duct for continuous temperature of 500°F and intermittent temperatures of 2000°F. Refer to the "Grease Duct Installation Manual L2502" for specific application information.

### OPERATING PRECAUTIONS

#### CREOSOTE AND SOOT – Formation and Need for Removal

When wood is burned slowly, it produces tar and organic vapors which combines with expelled moisture to form creosote. The creosote vapors condense in the relatively cool chimney flue of a slow burning fire. As a result, creosote residue accumulates on the flue lining. If ignited, this creosote makes an extremely hot fire. For this reason, the chimney should be inspected at least once every two months during the heating season to determine if a creosote or soot buildup has occurred. If creosote or soot has accumulated, it should be removed to reduce risk of chimney fire.

A licensed or qualified chimney sweep should be contacted to clean the chimney. Contact local building or fire officials about restrictions and installation inspection in your area. Adequate clearance is required around cleanouts to assure accessibility for removal of caps and products accumulated within the chimney.

**NOTE: Dimensions in these instructions are in American standard (feet and inches), with Metric (mm) in parenthesis except stated otherwise.**

## CHIMNEY ENVIRONMENT

It is suggested that a chimney being installed in a corrosive atmosphere be constructed of Type 316 stainless steel. Type 316 stainless is resistant to corrosion and will add to the life expectancy of the installation. Chemicals containing halogen compounds should not be allowed to contaminate the combustion air supplied to the heating equipment. Storage or use of chemicals containing chlorine or chlorides in the vicinity of equipment, or the presence of these compounds in the fuel, or combustion air supply may lead to early deterioration of the chimney.

Chemicals which may cause attack on chimney materials include (but are not limited to):

- chlorinated or halogenated dry cleaning solutions,
- fluorocarbon refrigerants,
- hydrochloric (muriatic), sulfuric or other acids,
- fluorocarbon aerosol propellants,
- vinyl plastics (when burned),
- chlorine bleach and cleaning solutions,
- titanium tetrachloride, or
- plating or etching baths or solutions.

Any of these chemicals passing through the combustion process produce acids which can corrode the heating equipment and the chimney.

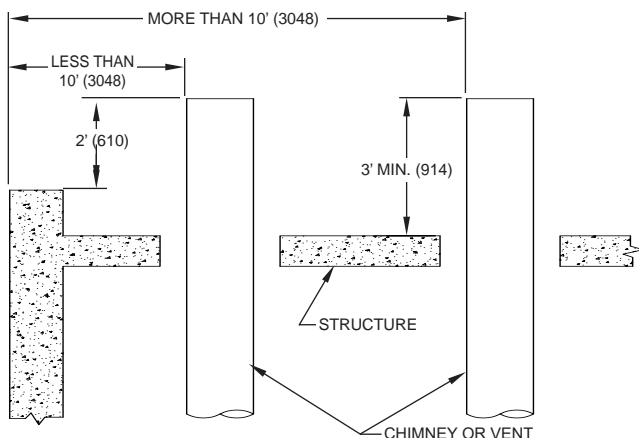
If corrosion is found, an immediate investigation should be undertaken of the entire area. Any corrosive materials should be removed to avoid future contamination. A contaminate-free atmosphere for combustion and ventilation air must be obtained. It may be necessary to pressurize the equipment room with its own air supply. Any surface discoloration should be carefully studied as it may be caused by contaminates in the fuel, or corrosion of mild steel components of the chimney system, the breeching system, or the equipment being vented and may be indicative of deterioration of other components of the heating system.

Whenever the local atmosphere is high in pollutants, constantly or intermittently, it is recommended that the chimney components be of all stainless steel construction. When chimney is exposed to the elements, it is recommended that the outer wall be either painted with one base coat and one finish coat of a heat resistant primer and paint, or that the outer wall be constructed of stainless steel.

## TERMINATION HEIGHT REQUIREMENTS

Model PIC/IPIC chimney is to terminate a minimum of 3' (914) above the highest point where it passes thru a roof of a building and a minimum of 2' (610) higher than any portion of a building within a horizontal distance of 10' (3.05m) (See FIG. 1).

**FIG. 1 - TERMINATION HEIGHT REQUIREMENTS**



## CLEARANCES – BOILERS AND ENGINES

### CAUTION–DO NOT ENCLOSE IN A CHASE OR PASSAGEWAY OF COMBUSTIBLE MATERIAL

For appliances operating with continuous exhaust temperatures up to 1400° F, where the chimney is installed in an open room or fully ventilated area on the same story as the appliance to which it is connected, Model PIC/IPIC Chimney shall be installed at a minimum of the clearance to combustibles as indicated in **TABLE 1**.

Except for installation in one or two family dwellings, a factory-built chimney that extends through any zone above that on which the connected appliance is located is to be provided with an enclosure having a fire resistance rating equal to or greater than that of the floor or roof assemblies through which it passes.

Metal-Fab Model PIC/IPIC Chimney can penetrate a combustible roof by utilizing the Roof Support Assembly (RSA) or Ventilated Thimble Assembly (VTA). All other parts are for attachment to non-combustible construction (i.e., floor guides, wall guides, plate or wall support assemblies).

**TABLE 1 - PIC/IPIC INSTALLATION CLEARANCES**

Insulation Thickness	Operating Temperature					
	1000°F Continuous (538°C) 1400°F Intermittent (760°C)		1400°F Continuous (760°C) 1800°F Intermittent (982°C)			
	PIC	IPIC-1	IPIC-2 IPIC-4	PIC	IPIC-1	IPIC-2 IPIC-4
<b>Exterior Wood Frame or Combustible Wall</b>						
Diameter:	6"	4" (102)	1" (25)	1" (25)	4" (102)	1" (25)
	8 - 16"	4" (102)	2" (51)	1" (25)	4" (102)	2" (51)
	18"	5" (127)	3" (76)	1" (25)	6" (152)	3" (76)
	20"	6" (152)	3" (76)	1" (25)	8" (204)	3" (76)
	22"	6" (152)	3" (76)	1" (25)	9" (229)	3" (76)
	24 - 26"	6" (152)	3" (76)	1" (25)	10" (254)	3" (76)
	28 - 32"	6" (152)	4" (102)	1" (25)	10" (254)	4" (102)
	34"	6" (152)	5" (127)	1" (25)	10" (254)	5" (127)
	36 - 40"	6" (152)	5" (127)	1" (25)	10" (254)	5" (127)
	42 - 48"	6" (152)	6" (152)	1" (25)	10" (254)	6" (152)
<b>Exterior Non-Combustible</b>						
Diameter:	6"	2" (51)	1" (25)	1" (25)	2" (51)	1" (25)
	8 - 18"	2" (51)	2" (51)	1" (25)	2" (51)	2" (51)
	20 - 42"	4" (102)	3" (76)	1" (25)	4" (102)	3" (76)
	44 - 48"	4" (102)	4" (102)	1" (25)	4" (102)	4" (102)
<b>Interior Wood or Other Combustibles</b>						
Diameter:	6"	4" (102)	1" (25)	1" (25)	4" (102)	1" (25)
	8 - 16"	4" (102)	2" (51)	1" (25)	4" (102)	2" (51)
	18"	5" (127)	3" (76)	1" (25)	6" (152)	3" (76)
	20"	6" (152)	3" (76)	1" (25)	8" (204)	3" (76)
	22"	7" (178)	3" (76)	1" (25)	9" (229)	3" (76)
	24"	8" (204)	3" (76)	1" (25)	10" (254)	3" (76)
	26"	9" (229)	3" (76)	1" (25)	10" (254)	3" (76)
	28 - 32"	10" (254)	4" (102)	1" (25)	10" (254)	4" (102)
	34"	10" (254)	5" (127)	1" (25)	10" (254)	5" (127)
	36 - 40"	10" (254)	5" (127)	3" (76)	10" (254)	5" (127)
	42 - 48"	10" (254)	6" (152)	3" (76)	10" (254)	6" (152)
<b>Fully Enclosed Combustibles (UL103-HT)</b>						
Diameter:	6"-14"	N/A	N/A	2" (51)	N/A	N/A
Fire Rated or Non-Combustible Chase	As necessary for installation and access, refer to NFPA 211.					

Note: The above figures represent air space, in inches, from outer surface to surroundings.

### NOTES:

1. False ceilings are a potential hazard and require firestopping. Chimneys passing through areas between ceiling and roof must be installed in fire-rated enclosures in accordance with local building codes.
2. Decorative shrouds at the termination of a factory built chimney shall not be permitted per NFPA 211.

## USE AND INSTALLATION OF INDIVIDUAL PARTS:

These instructions comprise both general and specific requirements for all parts in the product line. Before specifying a design or beginning an installation, these instructions should be carefully reviewed.

## PIPE WEIGHT

The average weight of the chimney, per foot of length, can be calculated using the following formula:

PIC:  $0.80 \times \text{diameter} = \text{lbs per foot}$   
 IPIC-1:  $0.95 \times \text{diameter} = \text{lbs per foot}$   
 IPIC-2:  $1.05 \times \text{diameter} = \text{lbs per foot}$   
 IPIC-4:  $1.45 \times \text{diameter} = \text{lbs per foot}$

Example: 8IPIC-2:  $1.05 \times 8 = 8.4 \text{ lbs per foot}$

Chimney design should make provisions for support adequate to ensure that chimney parts are not overloaded.

## PART NUMBERS

These instructions identify Model PIC/IPIC parts by name of part number in the text and illustrations. Actual parts also carry a flue diameter prefix and a three digit "CTO" suffix which defines the materials of construction, such as 24IPIC30-461 for a 24-inch diameter double wall pipe section 30 inches long with Type 304 stainless steel inner wall, Type 316 stainless steel outerwall and a 1" insulation. (See Table 2 for further explanations of CTO codes).

**TABLE 2**

1st DIGIT (INNER WALL)	2nd DIGIT (OUTER WALL)	3rd DIGIT (INSULATION)
4 = 304 S/S 6 = 316 S/S	A = ALUMINIZED STEEL 4 = 304 S/S 6 = 316 S/S	0 = 1" AIR SPACE 1 = 1" INSULATION 2 = 2" INSULATION 4 = 4" INSULATION

## JOINT ASSEMBLY

The Model PIC/IPIC joint sealing system is designed for quick and easy installation. For most applications follow Steps 1 through 6. (For High Pressure applications, see additional steps.)

**NOTE:** When assembling 6"- 48" diameter PIC/IPIC Chimney, always install the female flue end elevated above the male flue end.

### STEP 1

Fill the channel of the flange band with the proper sealant and install below flange of first pipe section.



**NOTE:** Sealant is to be supplied by Metal-Fab. See **TABLE 3** on **Page 23** for number of tubes per joint.

**CAUTION: THE USE OF ANY OTHER SEALANT ON THE FLANGE SURFACE WILL NEGATE ALL LISTINGS OF THE PRODUCT AND IMPAIR THE SEALING EFFECTIVENESS.**

### STEP 2

Apply a continuous bead of proper sealant in the corner of the sleeve and flange.

**NOTE:** For gas temperatures up to 600°F, use P077 sealant.

For gas temperatures over 600°F, use P071 sealant.

**For high pressure applications, including ALL engine or turbine exhaust applications, use P071 sealant.**



### STEP 3

Join the two flanged ends of the pipe sections.



### STEP 4

Install the flange band around the flanges.

**NOTE:** Do not locate V-Clamp hardware at the bottom side of horizontal duct joints.

When installing flange band, tap lightly with hammer around periphery of band while tightening draw screws. This helps to align flanges for the best seal. Do not overtighten draw screws.



**NOTE:** Allow sealant to cure 24 hours before operating appliances.

### STEP 5

**(IPIC Installations Only)**

Pack the void between inner and outer walls with insulation strips.

INSULATION STRIPS (PROVIDED)



### STEP 6

Secure the outer casing with the closure band.

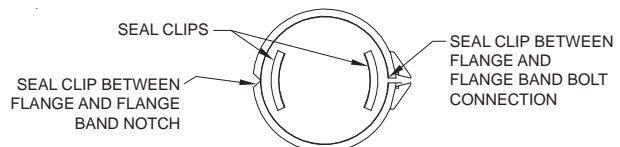
When system is installed outdoors, the upper side (upper half in the horizontal position) of the closure band bead should be sealed with P077 sealant to make the casing watertight.



**For all ENGINE EXHAUST and other HIGH PRESSURE applications, perform Steps 1 through 3 above, then:**

4. Install the seal clip(s) on the flanges 6", 8" and 10" only. (See **TABLE 4**).

**Note: 6" & 8" require two seal clips located as shown.**



5. Install the flange band around the flanges making sure the joint is located so the seal clip overlaps both edges of the joint.

6. Fill the space behind the flange band on both sides of the flange with P071 pressure sealant (See **FIG. 3**).

7. Pack void between inner and outer walls with insulation strips for IPIC installations.

8. Secure the outer casing with the closure band. Apply sealant to closure band for exterior applications only.

See **JOINT ASSEMBLY** and **FIG. 3** for Illustrations of the joining process and finished joint.



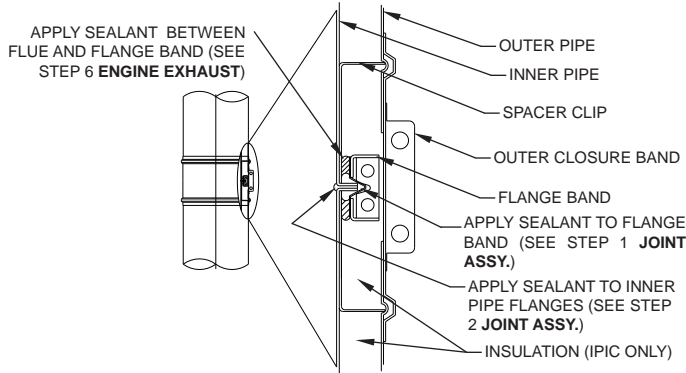
TABLE 4 - SEAL CLIPS REQUIRED PER JOINT FOR PRESSURE SEALS		
Pipe Diameter	No. of Clips	Part No.
6"-8"	2	SCK6-8*
10"	1	SCK10

\*SCK6-8 contains 2 seal clips

Properly sealed joints are gas tight and resistant to water, oil solvents and acids (except hydrofluoric).

**IMPORTANT: P071 Sealant must cure at operating temperatures above 500°F at a minimum 3-hr curing time.**

**FIG. 3 – ASSEMBLED MODEL PIC JOINT**



**SUPPORT LIMITS - SUPPORT SPACING**

TABLE 5 provides the maximum vertical distances between supports for various support types.

**TABLE 5**

Support Method	Maximum Supported Height (meter)			
	PIC	IPIC-1	IPIC-2	IPIC-4
Wall Support	40' (12.19m)	34' (10.4m)	30' (9.1m)	29' (8.8m)
Pier or Appliance Outlet	100' (30.48m)	85' (25.9m)	75' (22.9m)	73'(22.3m)
Plate Support Assembly	100' (30.48m)	85' (25.9m)	75' (22.9m)	73'(22.3m)
Roof Support Assembly	30' (9.1m)	25' (7.6m)	22' (6.7m)	22' (6.7m)
Stack Support Assembly	100' (30.48m)	100' (30.48m)	100' (30.48m)	100' (30.48m)
Fan Adapter Plate	6"-36" dia. 20' (6m)	6"-28" dia. 20' (6m) 30"-36" dia. 15' (4.6m)	6"-26" dia. 20' (6m) 28"-36" dia. 15' (4.6m)	6"-18" dia. 20' (6m) 20"-26" dia. 15' (4.6m) 28"-36" dia. 10' (3m)

**GUIDE SPACING**

TABLE 6 provides maximum distance between guides for chimney installed inside building. (For exterior installations, See TABLE 7 and FIG. 37.) These numbers represent ALL diameters and vary depending on the amount of insulation.

**TABLE 6**

Maximum Unsupported Horizontal Spacing:	
PIC	12'-6" (3.8m)
IPIC-1	10' (3.1m)
IPIC-2	9' (2.7m)
IPIC-4	9' (2.7m)
Maximum Unsupported Vertical Spacing Below Roof Line:	
PIC	25' (7.6m)
IPIC-1	21' (6.4m)
IPIC-2	19' (5.8m)
IPIC-4	18' (5.5m)

**TABLE 7 - PIC & IPIC-1 GUYING REQUIREMENTS**

Pipe Diameter	"A"	"B"
6"	17' 0" (5.18m)	8' 6" (2.59m)
8"	17' 6" (5.33m)	8' 9" (2.67m)
10"	18' 6" (5.64m)	9' 3" (2.82m)
12"	20' 0" (6.10m)	10' 0" (3.05m)
14"	21' 0" (6.40m)	10' 6" (3.20m)
16"	22' 0" (6.71m)	11' 0" (3.35m)
18"	23' 0" (7.01m)	11' 6" (3.51m)
20"	24' 0" (7.32m)	12' 0" (3.66m)
22"	24' 6" (7.47m)	12' 3" (3.73m)
24"	25' 0" (7.62m)	12' 6" (3.81m)
26"	26' 0" (7.92m)	13' 0" (3.96m)
28"	27' 0" (8.23m)	13' 6" (4.11m)
30"	27' 0" (8.23m)	13' 6" (4.11m)
32"	28' 6" (8.69m)	14' 3" (4.34m)
34"	29' 0" (8.84m)	13' 6" (4.11m)
36"	30' 0" (9.14m)	15' 0" (4.57m)
38"	30' 6" (9.30m)	15' 3" (4.64m)
40"	31' 0" (9.45m)	15' 6" (4.72m)
42"	32' 0" (9.75m)	16' 0" (4.88m)
44"	33' 6" (9.91m)	16' 3" (4.95m)
46"	33' 6" (10.21m)	16' 9" (5.10m)
48"	34' 6" (10.52m)	17' 3" (5.26m)

**TABLE 7 - IPIC-2 GUYING REQUIREMENTS**

Pipe Diameter	"A"	"B"
6"	10' 6" (3.20m)	7' 11" (2.41m)
8"	12' 0" (3.66m)	8' 5" (2.57m)
10"	13' 3" (4.04m)	8' 11" (2.72m)
12"	14' 6" (4.42m)	9' 5" (2.87m)
14"	15' 11" (4.85m)	9' 11" (3.02m)
16"	17' 0" (5.18m)	10' 6" (3.20m)
18"	18' 3" (5.56m)	11' 0" (3.35m)
20"	19' 6" (5.94m)	11' 6" (3.51m)
22"	20' 2" (6.15m)	11' 10" (3.61m)
24"	20' 9" (6.32m)	12' 3" (3.73m)
26"	21' 5" (6.53m)	12' 6" (3.81m)
28"	22' 1" (6.73m)	13' 1" (3.99m)
30"	22' 8" (6.91m)	13' 5" (4.09m)
32"	23' 4" (7.11m)	13' 10" (4.22m)
34"	24' 0" (7.32m)	14' 3" (4.34m)
36"	24' 7" (7.49m)	14' 7" (4.45m)
38"	24' 7" (7.49m)	14' 11" (4.55m)
40"	24' 7" (7.49m)	15' 3" (4.64m)
42"	24' 7" (7.49m)	15' 9" (4.80m)
44"	24' 7" (7.49m)	16' 3" (4.95m)
46"	24' 7" (7.49m)	16' 6" (5.03m)
48"	24' 7" (7.49m)	17' 0" (5.18m)

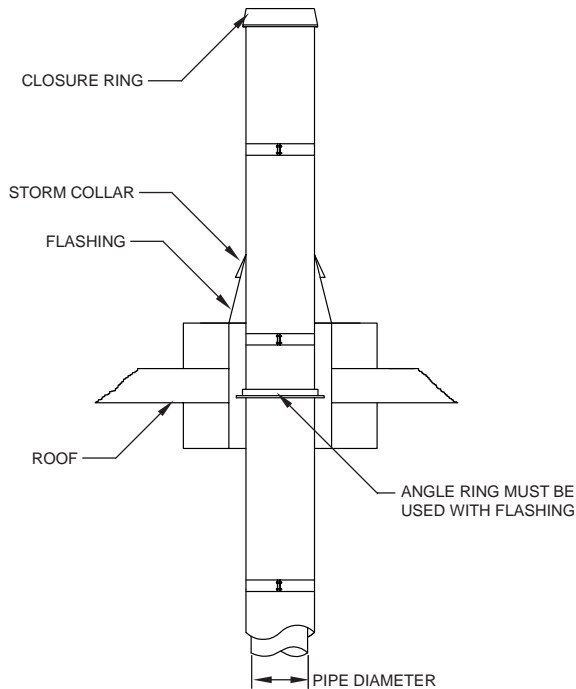
**TABLE 7 - IPIC-4 GUYING REQUIREMENTS**

Pipe Diameter	"A"	"B"
6"	8' 3" (2.51m)	6' 8" (2.03m)
8"	9' 7" (2.92m)	7' 3" (2.21m)
10"	10' 9" (3.28m)	7' 9" (2.36m)
12"	11' 11" (3.63m)	8' 4" (2.54m)
14"	13' 2" (4.01m)	8' 11" (2.71m)
16"	14' 2" (4.32m)	9' 6" (2.90m)
18"	15' 4" (4.67m)	10' 1" (3.07m)
20"	16' 4" (4.98m)	10' 8" (3.25m)
22"	17' 0" (5.18m)	11' 0" (3.35m)
24"	17' 7" (5.36m)	11' 6" (3.51m)
26"	18' 2" (5.54m)	11' 10" (3.61m)
28"	18' 9" (5.72m)	12' 4" (3.76m)
30"	19' 4" (5.89m)	12' 8" (3.86m)
32"	19' 11" (6.07m)	13' 2" (4.01m)
34"	20' 6" (6.25m)	13' 6" (4.11m)
36"	21' 0" (6.40m)	13' 11" (4.24m)
38"	21' 0" (6.40m)	14' 3" (4.34m)
40"	21' 0" (6.40m)	14' 8" (4.47m)
42"	21' 0" (6.40m)	15' 2" (4.62m)
44"	21' 0" (6.40m)	15' 8" (4.78m)
46"	21' 0" (6.40m)	16' 0" (4.88m)
48"	21' 0" (6.40m)	16' 5" (5.00m)

## CHIMNEY ABOVE ROOF

When chimney is extended above roofline, special consideration should be given to support and guying requirements. Use of a standard or variable pitch flashing requires that the chimney be stabilized to resist side loading. **FIG. 4 and 8** depict methods of protecting a flashing from side loads using a full angle ring or plate support. Ventilated thimble and roof support assemblies include lateral support rings, and additional guidance at the roofline is not required.

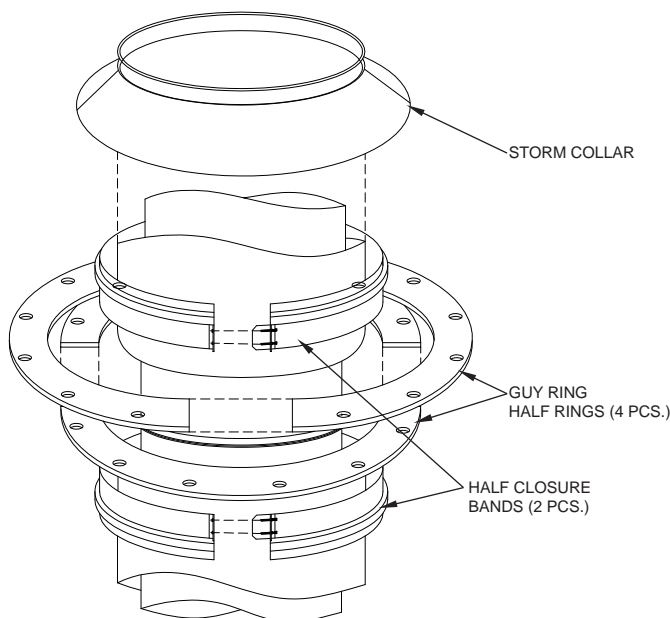
**FIG. 4 – FULL ANGLE RING FOR LATERAL SUPPORT**



## GUY RING (GR)

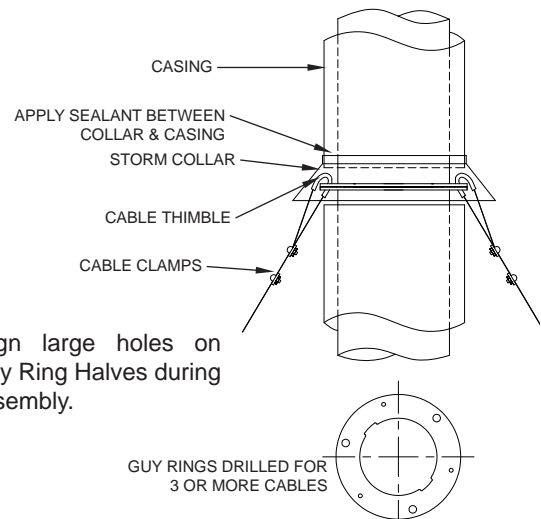
Chimneys that extend above the roof, or are installed in severe weather regions, may require a guy ring (GR) to enable the chimney to resist wind loads. The guy ring is connected to the building or other structure by means of cables or braces. **TABLE 7** provides the spacing between guy rings and freestanding height for Model PIC/IPIC Chimney.

**FIG. 5 - PIC/IPIC GUY RING, EXPLODED VIEW**



The guy ring consists of four (4) identical half rings with hardware to secure them together, two (2) half closure bands and a storm collar (**FIG. 5**). Select the joint where the guy ring is to be located and assemble the inner wall joint (Steps 1 to 6 under **JOINT ASSEMBLY** on Page 4). Sandwich the flange band between the guy rings with the joints of the top and bottom rings 90° apart and the cutouts aligned. Clamp the guy ring with the nuts and bolts provided. Install the half closure bands above and below the guy ring, then attach the cables or braces (See **FIG. 6**). Install the storm collar above the upper half closure. The collar should be caulked with sealant to prevent water entry.

**FIG. 6 – GUY RING CABLE ATTACHMENT**



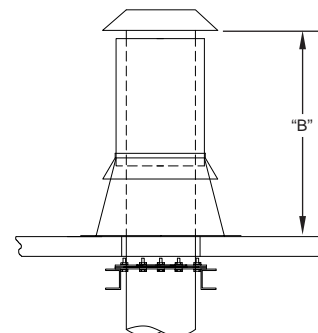
**NOTE:** Align large holes on Guy Ring Halves during assembly.

**NOTE:** Cable, cable clamps and cable thimble supplied by others.

Cable or braces (supplied by the installer) should be slightly loose to allow for thermal expansion for single guy ring installations (**FIG. 8**) or be equipped with tensioning springs on multiple guy ring installations (**FIG. 9**). To reduce the effect of thermal expansion on the guy cables or braces, a fixed-point support (plate or wall support assembly) may be installed immediately below the roofline as shown in **FIG. 8**.

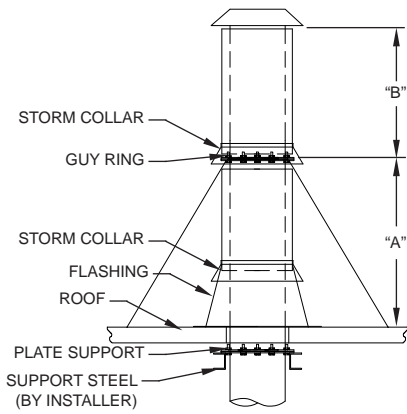
**NOTE:** When chimney is installed outside building, adjacent to wall, spacing between guides is equal to dimension “A” in **TABLE 7** (Refer to **FIG. 37** on Page 15).

**FIG. 7 – MAXIMUM FREE-STANDING HEIGHT ABOVE ROOF**



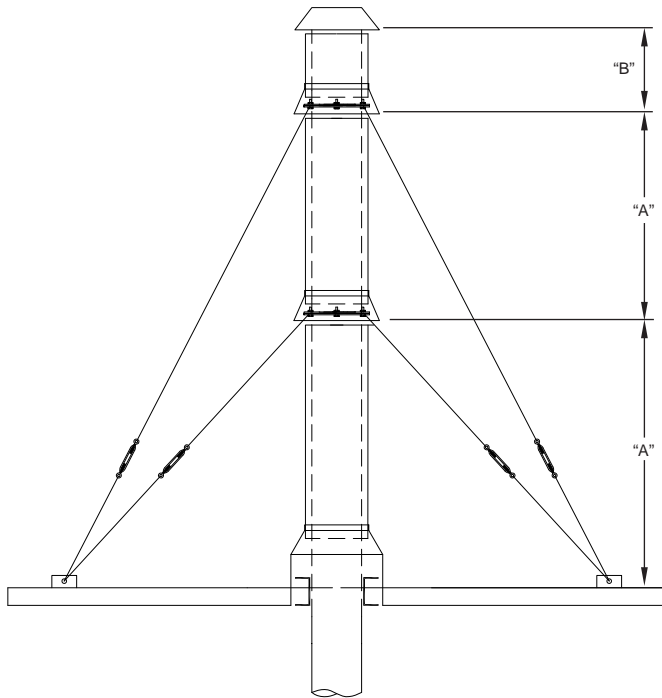
**NOTE:** See **TABLE 7** for “B” dimensions.

**FIG. 8 – GUYING FOR SINGLE SECTION**



**NOTE:** See TABLE 7 for “A” and “B” dimensions.

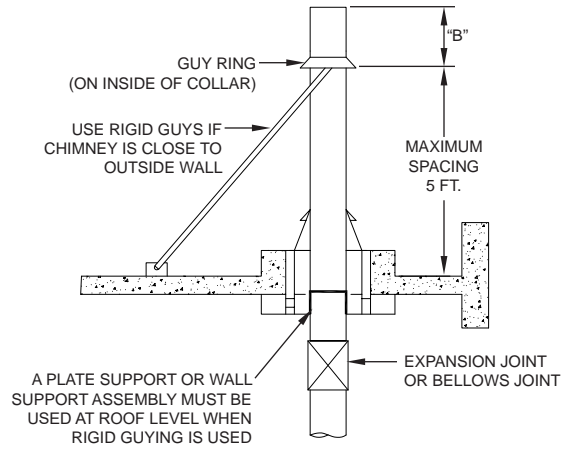
**FIG. 9 – CHIMNEY GUYING REQUIREMENTS**



**NOTE:** See TABLE 7 for “A” and “B” dimensions.

Cables should be spaced at or near 120° intervals (3 cables) or 90° (4 cables). Rigid bracing requires two (2) braces spaced between 60° and 150° apart. Maximum spacing between the fixed support and the guy ring is 5 feet when rigid bracing is used (See FIG. 10).

**FIG. 10 – HEIGHT LIMITS FOR RIGID GUYING**



**NOTE:** See TABLE 7 for “B” dimensions.

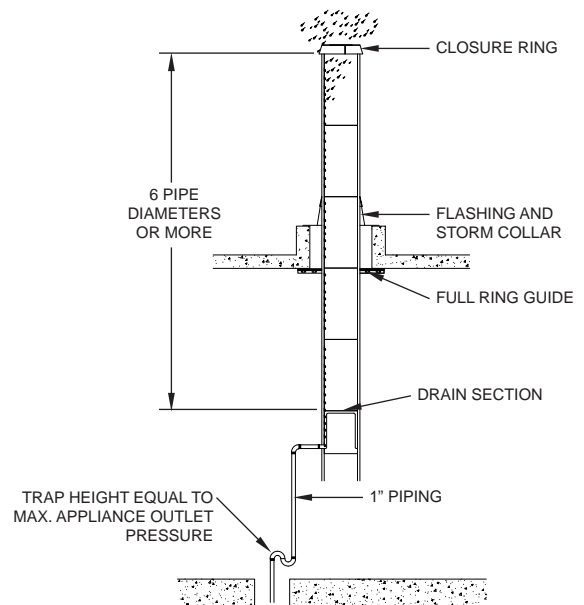
**PIPE LENGTHS (9, 18, 30, 42)**

Model PIC/IPIC pipe is available in 4 standard lengths: 9” (229), 18” (457), 30” (762) and 42” (1067). Pipe sections are joined, using appropriate sealant, to make up desired length of run. These sections may be modified by use of nipples or couplings to accept auxiliary equipment such as temperature probes or smoke monitors. Consult factory or your local representative to obtain information regarding such modifications.

**DRAIN SECTION (DS)**

A drain section is a special variation of an 18” (457) pipe length with provision to drain rain or condensate from the chimney. The pipe flue is equipped with an annular catch ring and a 1” (25) NPT nipple extending through the casing for attachment of drain piping. The drain piping should include a water leg of a height at least equal to the maximum expected operating pressure at the appliance outlet to avoid allowing flue gases to vent through the drain. Drain section should be installed indoors to prevent freezing (See FIG. 11).

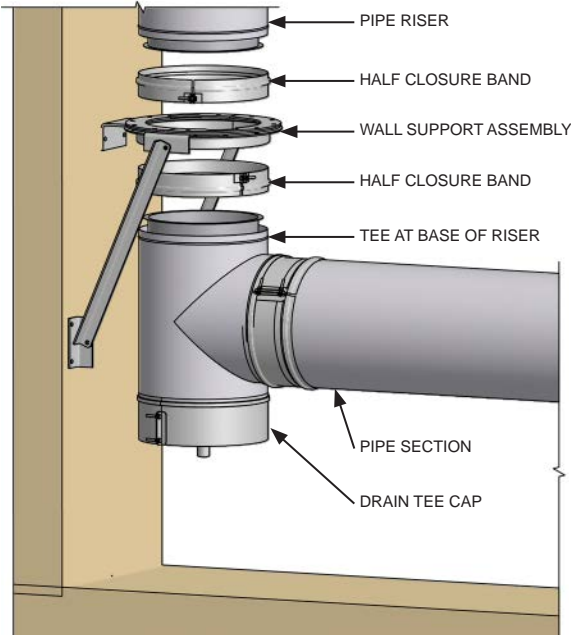
**FIG. 11 – DRAIN SECTION INSTALLATION**



### STANDARD 90° TEE (90MT)

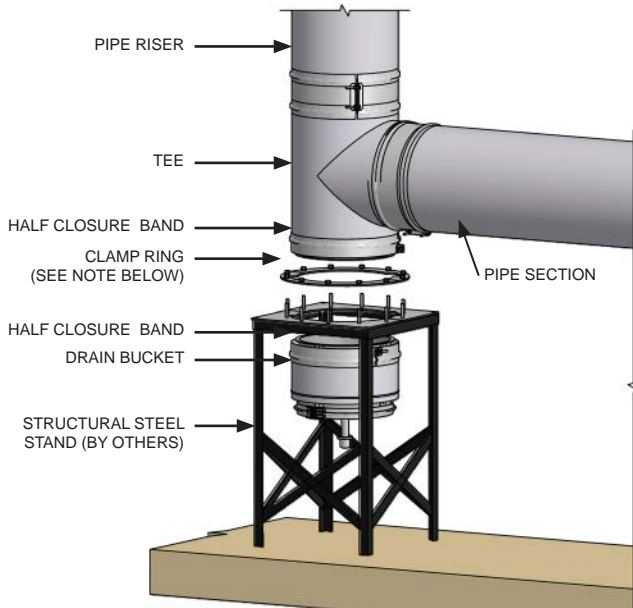
The 90° Manifold Tee (90MT) may be used to connect horizontal to vertical when a cleanout access or drain is desired. If more than 1/4" (6) of thermal expansion is expected between the tee and the next fixed support point (the appliance outlet, for example), the tee should be protected from bending moments by use of an expansion joint or bellows joint. See the sections on those fittings for additional information about compensation for thermal expansion.

**FIG. 12 – SUSPENDED TEE**



When a tee is used at the base of a riser, the preferred location for support is above the tee, thus suspending the tee (FIG. 12). If it is not possible to suspend the tee, it may be supported from the base of the tee (FIG. 13). When this type of support is necessary, access to the drain cap may be hindered. A drain bucket should be used under the tee to allow access to the tee cap.

**FIG. 13 – BASE SUPPORTED TEE**



### DRAIN TEE CAP (TC), CLEANOUT CAP

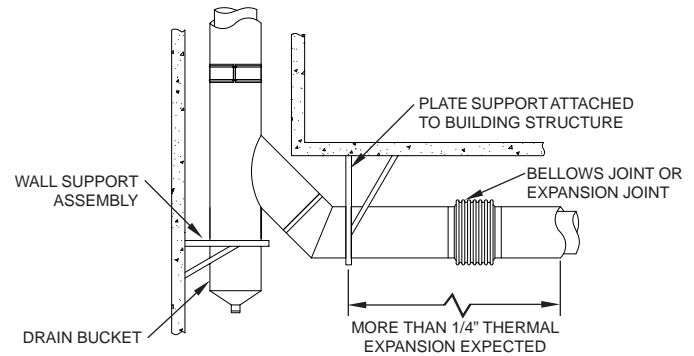
The unused port of a tee must be closed to prevent leakage of flue gases. A drain tee cap is used to close the tee and drain condensation or rainwater when the tee is installed at the base of a rise. When the tee is to be used for cleanout or access purpose only, a cleanout cap (TCN) is recommended. Both the drain tee cap and the cleanout cap are equipped with closures, which serve the dual purpose of maintaining the double wall clearance to combustible and giving the cap a finished appearance.

The drain tee cap's drain nipple must be connected to a suitable disposal point. Any rain entering the chimney will wash down and remove any combustion residue from the chimney flue. The resulting effluent may be corrosive. The tee cap must be sealed at the connection to the tee using the appropriate sealant for the application. This will assure that moisture will drain through the drain nipple, as intended.

### 45° MANIFOLD TEE (45MT), DOUBLE LATERAL (DL)

For systems where minimizing flow resistance is desirable or critical, a manifold tee having a 45° entrance to the trunk is available. When used to make 90° turns, an additional 45° elbow is required. It is particularly important to isolate the 45° manifold tee from the effects of thermal expansion. This isolation is typically accomplished by the use of a 2-axis support (See FIG. 14). Otherwise, the installation details and precautions are similar to those for the 90° manifold tee.

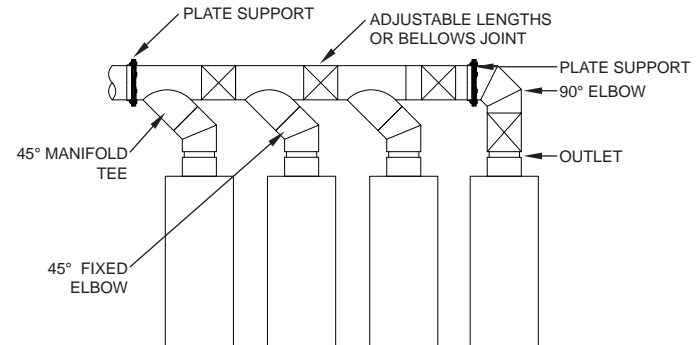
**FIG. 14 - TWO-AXIS SUPPORT METHOD**



### MULTIPLE APPLIANCE BREECHINGS (HEADERS)

When 90° or 45° manifold tees are used to manifold multiple appliances together, it is important to make provisions for expansion of the manifold. An expansion joint should be installed between tees (See FIG. 15). The manifold must be supported properly by means of plate supports or wall support assemblies arranged to protect the tees from bending forces.

**FIG. 15 – LATERAL TEE MANIFOLD**



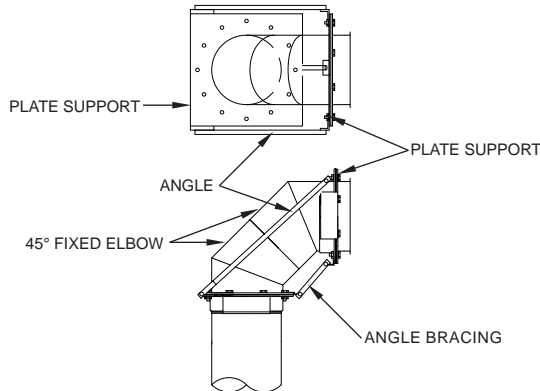
### 30°, 45° OR 90° FIXED ELBOWS (30L) - (45L) - (90L)

Elbows are not designed to resist bending loads and must be protected by structural reinforcement. FIG. 16 depicts some alternative methods for protection of elbows. Elbows may be

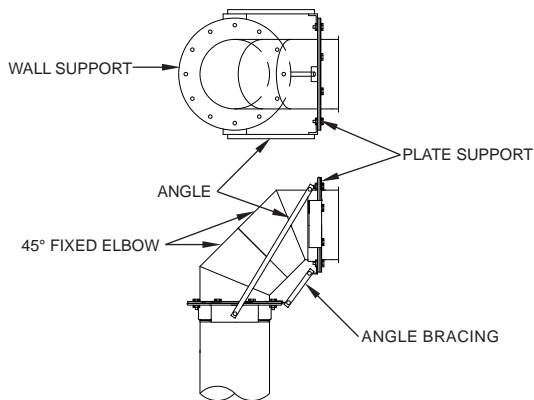


used singly or in combination to provide turns of 30, 45, 60, 75, or 90 degrees. For engine or turbine exhaust systems, it is recommended that 90° turns be accomplished by using two (2) 45° elbows or a combination of one 45° elbow and one 45° manifold tee to minimize flow resistance.

**FIG. 16 – METHODS OF STRUCTURAL REINFORCEMENT FOR ELBOWS**



2-45° ELBOWS REINFORCED WITH PLATE SUPPORTS

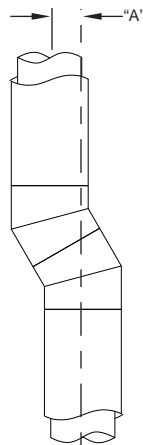


2-45° ELBOWS REINFORCED WITH WALL SUPPORTS

**CHIMNEY OFFSETS**

Offsets should be avoided except when there is no other way to route the chimney. When an offset must be used, good design indicates that the angle used should be the minimum possible (See FIG. 18). If the appliance currently burns solid fuel or is capable of being converted to burn solid fuel, the offset cannot exceed 30 degrees. No more than 2 offsets (4 elbows) may be used.

**FIG. 17 — MINIMUM ELBOW OFFSETS (REFER TO TABLE 8)**



**TABLE 8** indicates minimum center to center offset for two elbows connected directly to each other.

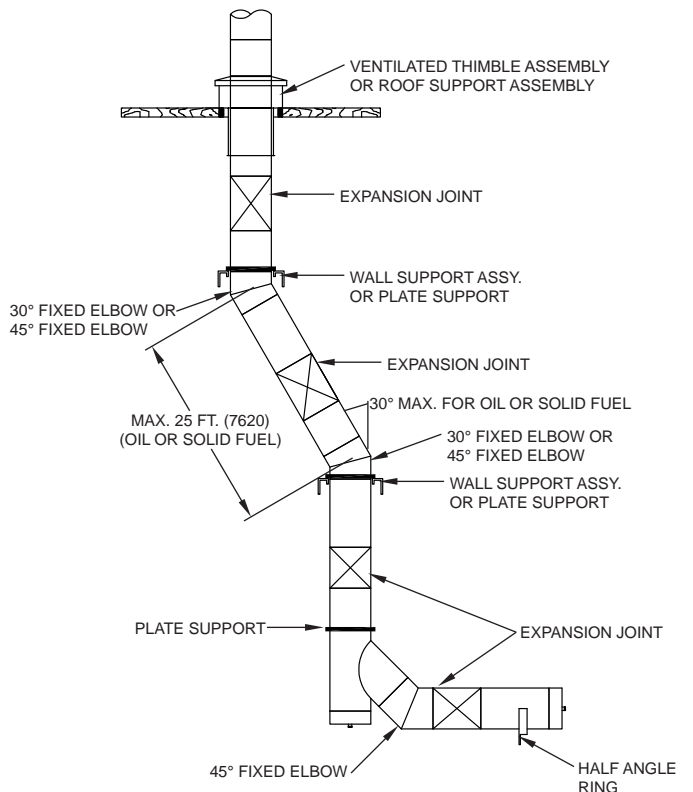
**TABLE 8 - MINIMUM OFFSETS**

MINIMUM ELBOW OFFSETS PIC & IPIC-1		
PIPE DIA.	"A" - 30° ELBOW	"A" - 45° ELBOW
6" thru 12"	6" (152)	9 7/8" (251)
14"	7 3/4" (197)	14 1/8" (359)
16" thru 24"	7 3/4" (197)	14 1/2" (368)
26" thru 36"	8 1/2" (216)	16 5/8" (422)
38" thru 48"	11" (279)	19 3/4" (503)

MINIMUM ELBOW OFFSETS IPIC-2		
PIPE SIZE	"A" - 30° ELBOW	"A" - 45° ELBOW
6" thru 10"	6" (152)	9 7/8" (251)
12"	7 3/4" (197)	14 1/8" (359)
14" thru 22"	7 3/4" (197)	14 1/2" (368)
24" thru 34"	8 1/2" (216)	16 5/8" (422)
36" thru 46"	11" (279)	19 3/4" (503)
48"	12 3/4" (324)	23 3/4" (602)

MINIMUM ELBOW OFFSETS IPIC-4		
PIPE SIZE	"A" - 30° ELBOW	"A" - 45° ELBOW
6"	6" (152)	9 7/8" (251)
8"	7 3/4" (197)	14 1/8" (359)
10" thru 18"	7 3/4" (197)	14 1/2" (368)
20" thru 30"	8 1/2" (216)	16 5/8" (422)
32" thru 42"	11" (279)	19 3/4" (503)
44" thru 48"	12 3/4" (324)	23 3/4" (602)

**FIG. 18 – SUPPORT FOR CHIMNEY OFFSETS**

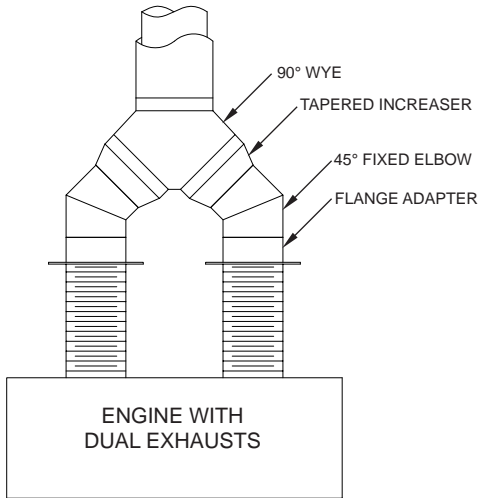


Bracing, above and below the elbows, is needed to avoid subjecting them to bending moments. In order for bracing to be effective, it must be rigidly attached to building members or foundation. The design of the structure used to attach supports must include the weight of the sloped section and whatever additional pipe is carried by the support. Additionally, an expansion joint or bellows joint is needed between the elbows to relieve thermal expansion stresses.

### 90° WYE (90Y)

The 90° wye is very useful when the vertical chimney is located between two appliances and a low-loss junction is desired. It is ideal for engine with dual-exhaust connections. The wye fitting may be suspended by a plate support or roof support assembly. Expansion joints or bellows joints should be used to protect the wye from thermal expansion stresses (See FIG. 19).

FIG. 19 – 90° WYE APPLICATION, DUAL EXHAUST



Installation procedure is as follows:

1. Loosen draw screw at gasket band and slide collar toward flanged end of tube. Do not remove collar from tube.
2. Slide unflanged end of tube into the upstream piece of pipe and make up joint between pipe and collar following the procedures outlined under heading JOINT ASSEMBLY on Page 4.
3. Pull flanged end of tube to the downstream piece of pipe and make up joint as above (See FIG. 20).
4. For IPIC, cut insulation to desired length and wrap inner pipe ensuring that it is covered completely before attaching half jackets.
5. Wrap two half jackets around joint with bead at the downstream end and punched edge overlapping plain edge by approximate 3/4" (19). **NOTE:** For horizontal installations the seams must be located at the top and bottom of the pipe, coat unpunched edge of casing with P077 sealant to waterproof the casing.
6. Install self-drilling screws (supplied with jacket) at punched holes through both layers at overlap. Exercise care that half jacket edges do not align with draw screws on flange bands and that no screws are installed in portion of jacket which is over casing of adjacent pieces of pipe (See FIG. 21). The screws shipped with the expansion joint are of the correct length to avoid penetrating the inner wall (flue) of the pipe. **Do not use any other screws to attach the casing.**

### EXPANSION JOINT (AL)

The expansion joint may be used to compensate for thermal expansion and to make up odd lengths. It is essential that sufficient installed length be allowed to compensate for abnormal, as well as normal, operating conditions. The expansion joint cannot be used to correct misalignment or to compensate for lateral movement or vibration. The use of the expansion joint in engine exhaust applications is not recommended.

An expansion joint is comprised of: (1) a collar that is 5 1/4" (133) long with a flange and vee band at one end and a graphite impregnated ring gasket at the other; (2) a 30" (762) long tube, flanged at one end, which fits into the 5 1/4" (133) collar; (3) an outer jacket consisting of two half jacket assemblies; and (4) loose insulation blanket to fill space between the tube and casing.

FIG. 20 – EXPANSION JOINT FLUE ASSEMBLY

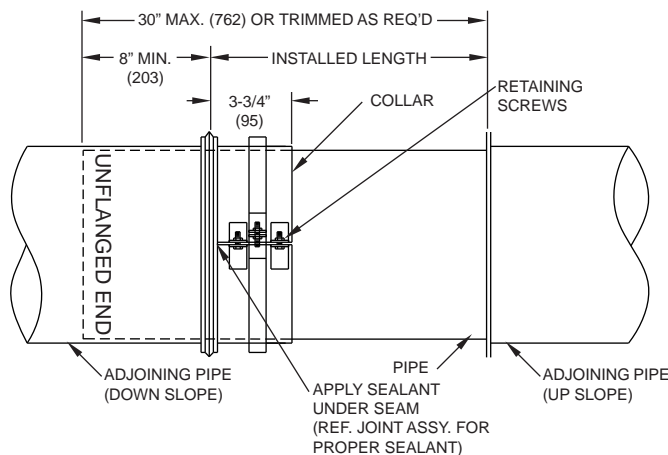
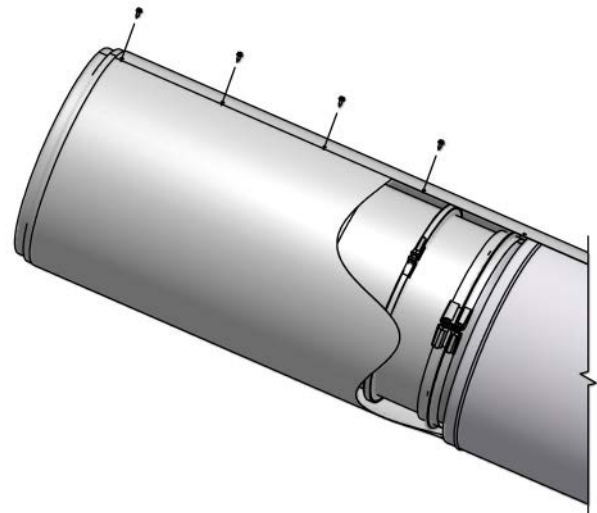


FIG. 21 - EXPANSION JOINT CASING ASSEMBLY



Note: Do not screw through casing of adjacent pipe.

**NOTES:**

1. It is recommended that the pipe on both sides of the expansion joint is supported or guided to assure that the expansion joint will not bind during operation.
2. Installation of an expansion joint adjacent to fittings, such as elbows, tees, wyes, or short pipe lengths is not recommended. However, it is not always possible to avoid these fittings. If an expansion joint must be joined to one of these fittings, the unflanged end of the tube should always point downward or towards downward slope.
3. Expansion joint must be installed with a flange to flange length of not more than 22". The minimum length for installation must take into account the amount of expansion that may occur during operation. Minimum length is calculated as follows:

$$\text{Expansion} = \text{Length (feet)} / 100 \times \text{Temperature Rise (°F)} / 100$$

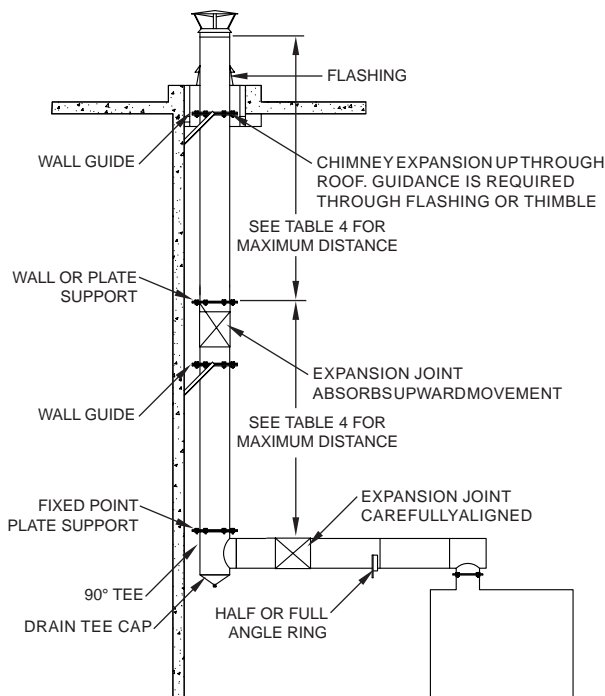
$$\text{Minimum Length} = \text{Expansion} + 6" \text{ (152mm)}$$

It is recommended that the temperature used in the above formula be at least 300°F higher than the expected normal operating temperature.

4. If inner tube is too long, it may be cut to length. Tube must be a minimum of 8" (203) longer than flange-to-flange length. Prior to installation of cut pipe, remove all burrs to ensure that interference does not occur.
5. Check gasket to ensure that it fits snugly without binding on inner pipe.
6. Outer jacket must move during expansion or contraction. Ensure that no screws are located where the jacket overlaps the casing of the adjacent pipe and that it is loose enough to move as needed. Alignment of the bead on the jacket with the bead on the adjacent pipe will ensure that the jacket stays in the proper location.
7. Note that the expansion joint will not support any weight in the vertical position. It should not be used unless both ends of run, where an expansion joint is installed, are anchored as fixed points.

FIG. 22 indicates appropriate locations for expansion joints in various orientations.

**FIG. 22 – EXPANSION JOINT LOCATIONS**

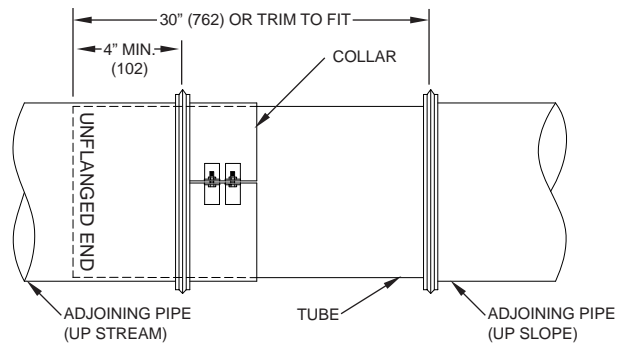


**VARIABLE LENGTH (VL)**

The function of the variable length is to make up odd lengths of pipe, which are not to be used for expansion compensation. The use of the variable length in engine exhaust applications is not recommended. The variable length is comprised of the following components: (1) a 3/4" (83) collar with a flange at one end used to clamp the flange at the desired length; (2) a 30" (762) long tube flanged at one end, which fits into the 3/4" (83) collar; (3) an outer jacket consisting of two half jacket assemblies; and (4) loose insulation blanket to fill space between the tube and casing.

A variable length can be installed at any flange to flange length from 4"-26" (102-660). If the flue is too long to fit into the adjacent section of pipe without interfering with the flow path, it should be trimmed to the desired flange to flange length plus 4" (102).

**FIG. 23 VARIABLE LENGTH FLUE ASSEMBLY**

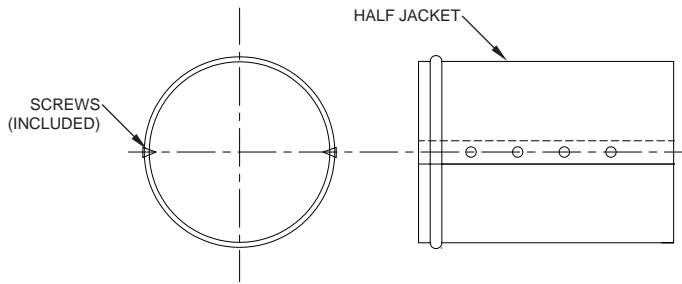


Installation procedure is as follows:

1. Loosen draw screw at collar and slide collar toward flanged end of tube. Do not remove collar from tube.
2. Slide unflanged end of tube into the upstream piece of pipe. Pull flanged end of tube to the downstream piece of pipe and make up joint as outlined under JOINT ASSEMBLY on Page 4.
3. Apply a thin coat of sealant, about 1" (25) wide at the plain end of the pipe where tube slides into mating pipe section. Press sealant into any gap between the tube and the mating pipe section. Apply sealant to flange of mating pipe (See FIG. 23).
4. Slide collar into position against flange of mating pipe. Fill flange band with sealant and install flange band.
5. Tighten bolts on clamp collar to complete installation. (For more positive seal, apply sealant to clamp collar slot and flared end of collar prior to tightening bolts).
6. For IPIC, cut insulation to desired length and wrap inner pipe ensuring that it is covered completely before attaching half jackets.
7. Wrap two half jackets around joint with bead at the downstream end and punched edge that overlapping the plain edge by approximately 3/4". Note: For horizontal installations, the seams must be located at the top and bottom of the pipe. Coat unpunched edge of casing with P077 sealant to waterproof the casing. Install self-drilling screws (supplied with jacket) at punched holes through both layers at overlap. Exercise care that half jacket edges do not align with draw screws on flange bands, and that no screws are installed in portion of jacket which is over casing of adjacent pieces of pipe (See FIG. 24). The screws shipped with the expansion joint are of the correct length to avoid penetrating the inner wall (flue) of the pipe.

**Do not use any other screws to attach the casing.**

**FIG. 24 – VARIABLE LENGTH CASING ASSEMBLY**



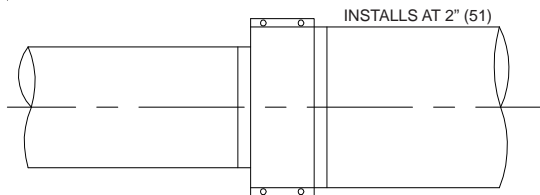
**NOTES:**

1. It is recommended that the pipe adjacent to the variable length is supported or guided to prevent sagging.
2. Installation of an variable length adjacent to fittings, such as elbows, tees, wyes, or short lengths is not recommended. However, it is not always possible to avoid these fittings. If an variable length must be joined to one of these fittings, the unflanged end of the tube should always point downward or towards downward slope.
3. A variable length may be installed with a flange to flange length between 4” and 26” (102 and 660) inclusive.
4. If inner tube is too long, it may be cut to length. Tube must be a minimum of 4” (102) longer than flange to flange length. Prior to installation of cut pipe, remove all burrs to ensure that interference does not occur.
5. Note that the variable length will not support any weight in the vertical position.

**STEP INCREASER (SI) AND TAPERED INCREASER (TI)**

Frequently, a diameter change is required in a chimney installation. To accomplish such a size change, a step increaser or tapered increaser may be used. These parts are usually used to provide an increase of size, as the name implies. However, they may be used to reduce the size of a run. Extreme caution should be exercised when reducing the size of a chimney. The resultant pressure drop may cause the chimney to mis-function and cause spillage of flue gases into the mechanical room. The step increaser should be used when the length of run available for the size change is restricted. The installed length of

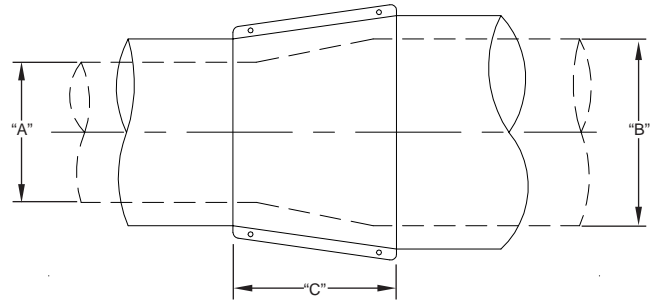
**FIG. 25 - STEP INCREASER (SI)**



**Note:** For IPIC, wrap increaser with insulation before attaching outer casing. Care must be taken to completely fill all gaps with insulation.

When sufficient length is available, use of a tapered increaser is recommended, since it causes a considerably less pressure drop than an equivalent step increaser. The tapered increaser uses 5 inches of length per incremental diameter change. The maximum length for a tapered increaser is 30” (762) or 6 pipe sizes. A tapered increaser is considered to have the same load strength as straight pipe (See FIG. 26).

**FIG. 26 - TAPERED INCREASER (TI)**

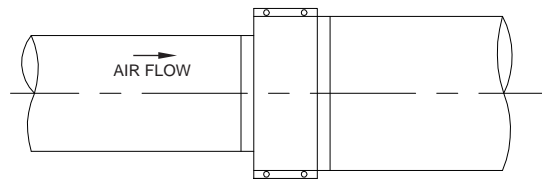


STEPS	1	2	3	4	5	6
"C" =	5" (127)	10" (254)	15" (381)	20" (508)	25" (635)	30" (762)

**TRANSITION BAND (TB)**

The transition band provides the necessary increase or decrease in casing diameter when change in insulation thickness occurs (FIG. 27).

**FIG. 27 - TRANSITION BAND (TB)**



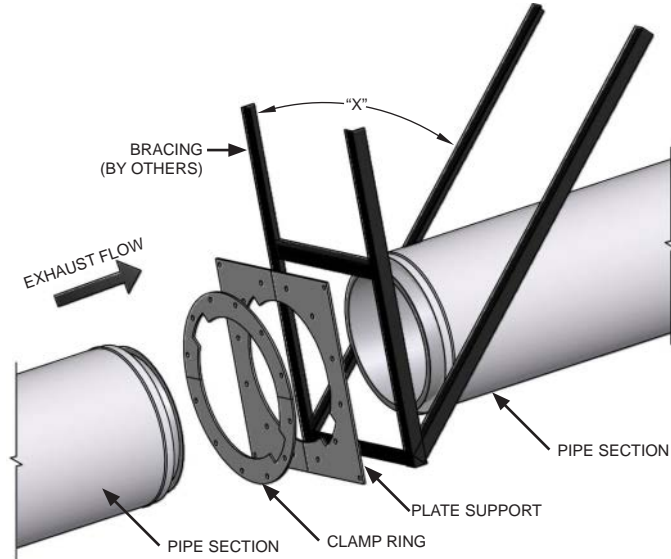
**Note:** Wrap pipe joint with insulation before attaching outer casing. Care must be taken to completely fill all gaps with insulation.

**PLATE SUPPORT (PS)**

**NOTE:** See TABLE 5 for maximum supported height.

The plate support assembly is designed to provide maximal support to vertical sections and to provide fixed-point support for horizontal sections. The plate support must be attached to the building structure or support with rigid structural members.

**FIG. 28 – PLATE SUPPORT BRACING REQUIREMENTS**

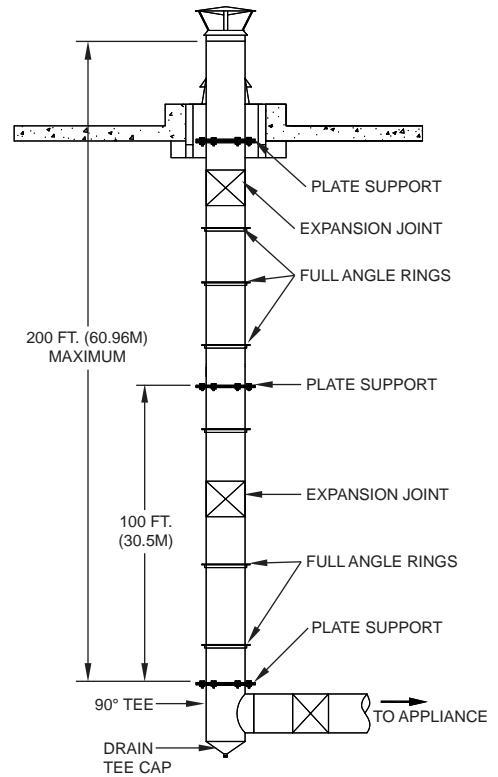


"X" is a minimum of 30° when bracing is used. A welded frame must be adequately attached to structural member for framework rigidity if bracing isn't used.

Pipe Diameter	PS Plate Thickness	Bracing for (PS) Plate Support Height of Stack	
		50' (15.24m)	100' (30.48m)
6" - 20"	3/16" (5)	1 1/4"x1 1/4"x1/8" (32x32x3)	2"x2"x1/4" (51x51x6)
22" - 36"	1/4" (6)	2"x2"x1/8" (51x51x3)	3"x3"x1/4" (76x76x6)
38" - 48"	1/4" (6)	3" (76) channel: 3"x1 1/2"x1/4" (76x38x6)	
Pipe Diameter	PS Plate Thickness	Framework for (PS) Plate Support Height of Stack	
		50' (15.24m)	100' (30.48m)
6" - 20"	3/16" (5)	1 3/4"x1 3/4"x1/8" (44x44x3)	3"x2"x3/16" (76x51x5)
22" - 36"	1/4" (6)	2"x2"x1/4" (51x51x6)	4"x3"x1/4" (102x76x6)
38" - 48"	1/4" (6)	3" channel: 3"x1 1/2"x1/4" (76x38x6)	

When the supported section is subject to thermal expansion or is in a vertical position, so that the plate support is weight bearing, the support structure must be braced with diagonal members or gussets to prevent deflection of the supported joint (See FIG. 28). Plate supports are usually located adjacent to fittings, such as tees or elbows, to protect the fitting from expansion stresses. Chimneys heights in excess of a single plate support capability can be resupported with additional plate support(s). An expansion joint must be used between support points (See FIG. 29).

**FIG. 29 – RESUPPORT REQUIREMENTS**

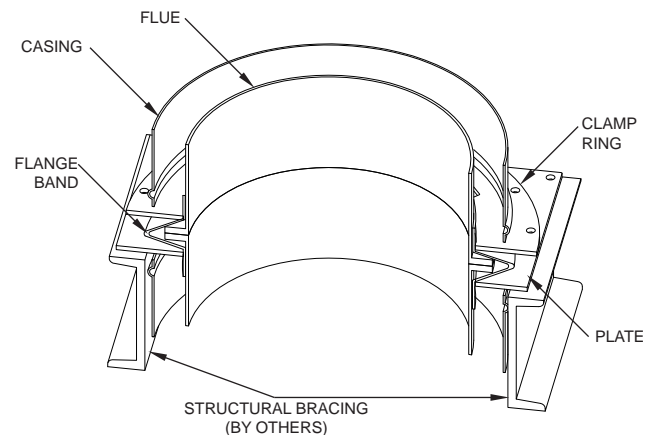


A plate support assembly is to be attached only to non-combustible construction such as block, concrete or steel with clearance that is adequate for installation and access.

**DO NOT ATTACH THE PLATE SUPPORT TO COMBUSTIBLE CONSTRUCTION.**

For maximum support, the entire perimeter of the plate support assembly must be attached to structural framing (See FIG. 30). Structural members are supplied by the installer.

**FIG. 30 – SECTIONAL DETAIL FOR PLATE SUPPORT**



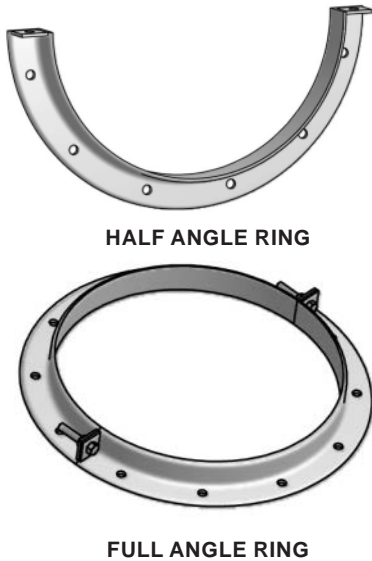
**NOTE:** Clamp ring sections and plate sections install at 90° angles.



**FULL ANGLE RING (FAR) AND HALF ANGLE RING (HAR)**

The full angle ring is used as a guide to prevent the chimney from flexing due to lateral loading. The angle ring is split for ease of installation. It is 1/8" larger in inside diameter than the outside diameter of the pipe to allow movement of the pipe inside the ring (See FIG. 31).

**FIG. 31 – FULL ANGLE RING & HALF ANGLE RING**

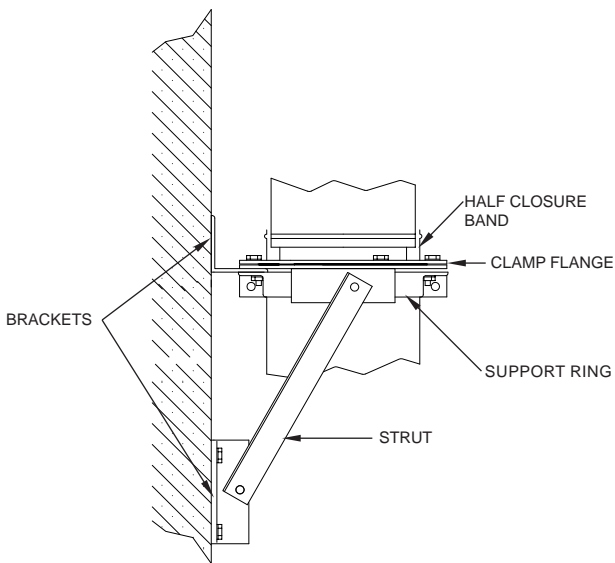


The half angle ring is used as a saddle in horizontal or sloped runs. It may be suspended either on rigid framework or soft frames, such as threaded rod. The half angle ring will not replace a plate support or other fixed support in horizontal runs. It should not be used as the sole support for the chimney.

**WALL SUPPORT ASSEMBLY (WSA)**

A wall support assembly consists of a full angle ring, two clamp rings, wall brackets and struts. The clamp rings sandwich a flange band at a pipe joint and are supported by the full angle ring (See FIG. 32).

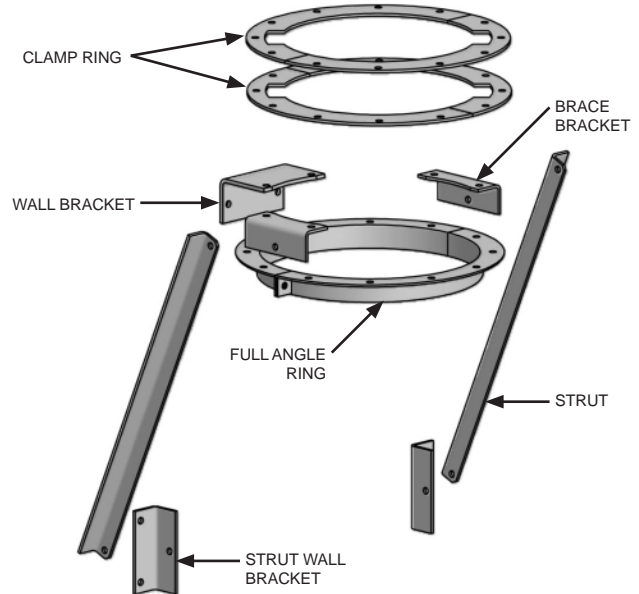
**FIG. 32 – WALL SUPPORT ASSEMBLY ASSEMBLED VIEW**



**Note:** For IPIC, wrap pipe joint with insulation before attaching half closure bands.

The clamp rings are installed with the splits 90° apart so that they support each other. The notches in the clamp rings are aligned with the draw screws of the flange band. The clamp rings and full angle ring are then bolted together with the hardware provided to form a rigid assembly (See FIG. 33).

**FIG. 33 WALL SUPPORT ASSEMBLY EXPLODED VIEW**



When attached to a non-combustible wall, with the brackets and struts, the wall support makes up a fixed-point in the chimney. An expansion joint is required between the wall support assembly and any adjacent fixed point.

Multiple wall support assemblies may be used, in conjunction with expansion joints or bellows joints, to support chimney heights in excess of the allowable height for a single wall support assembly.

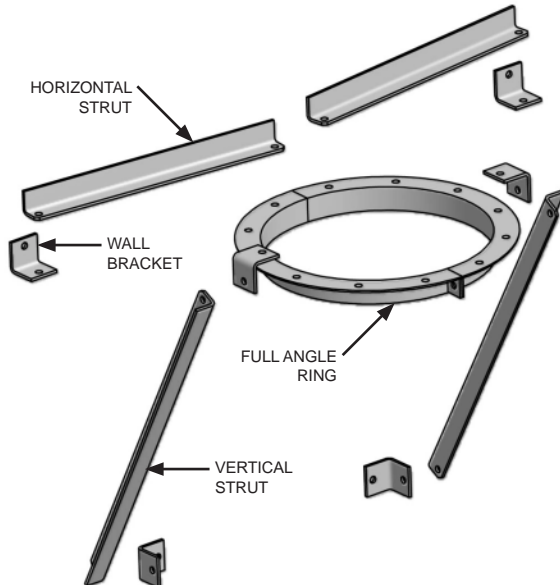
**DO NOT ATTACH THE WALL SUPPORT ASSEMBLY TO COMBUSTIBLE CONSTRUCTION.**

**WALL GUIDE (WG)**

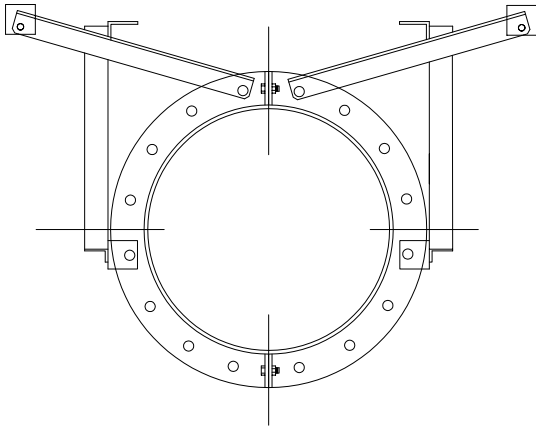
The wall guide is designed to compliment the wall support assembly. It is used as a lateral guide to prevent the chimney from flexing due to lateral loading.

The wall guide consists of a full angle ring with wall brackets and struts (See FIG. 34 & 35).

**FIG. 34 – WALL GUIDE ASSEMBLY EXPLODED VIEW**

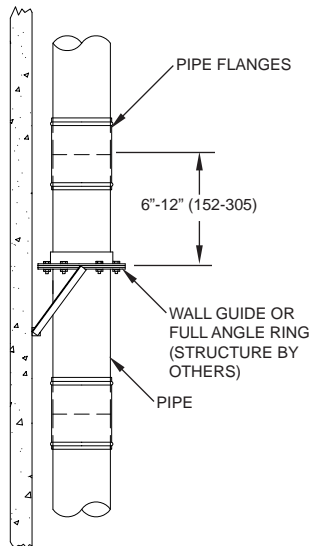


**FIG. 35 – WALL GUIDE ASSEMBLED VIEW**



The proper location for a wall guide is immediately below the outer closure band near a pipe joint. The outer band must be able to move away from the wall guide when thermal expansion occurs (See FIG. 36).

**FIG. 36 – WALL GUIDE LOCATIONS**

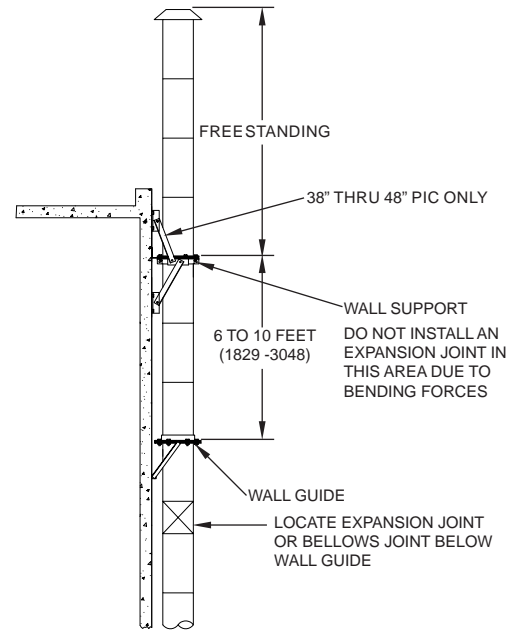


**DO NOT ATTACH THE WALL GUIDE TO COMBUSTIBLE CONSTRUCTION.**

**SPECIAL CONSIDERATIONS**

When a wall support assembly is used to support a chimney on an exterior wall, wind loading must also be considered. Below the highest wall support assembly, the chimney must be resupported at intervals not greater than 40' (12.19m) (See TABLE 5). The chimney must be equipped with wall guides between each wall support assembly. Guide spacing is in accordance with maximum vertical spacing in TABLE 6 on Page 5. Additionally, a wall guide must be located between 6' and 10' (1.83m and 3.05m) below the highest wall support to stabilize the freestanding portion of the chimney above the wall support assembly (See FIG. 37).

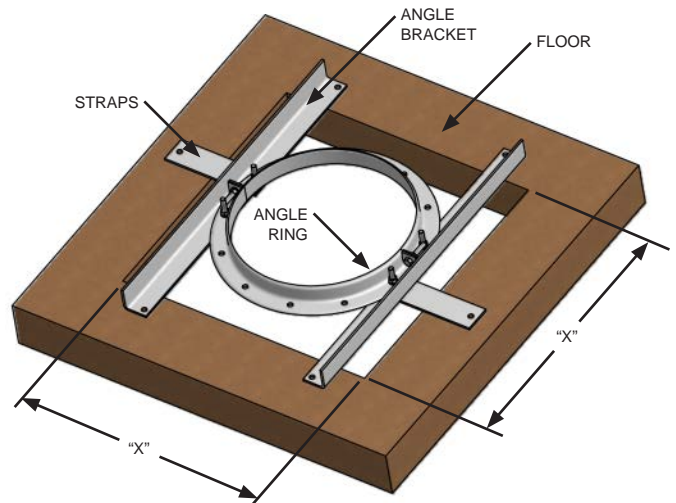
**FIG. 37 – SPECIAL CONSIDERATIONS FOR CHIMNEY ON OUTSIDE WALL**



**FLOOR GUIDE (FG)**

The floor guide is similar in function to a wall guide or full angle ring, but is modified specially for use at floor penetrations. The angle brackets and straps hold the guide centered in the floor penetration (See FIG. 38). Maximum floor opening "X" is Duct I.D. + 10" (254).

**FIG. 38 – FLOOR GUIDE**

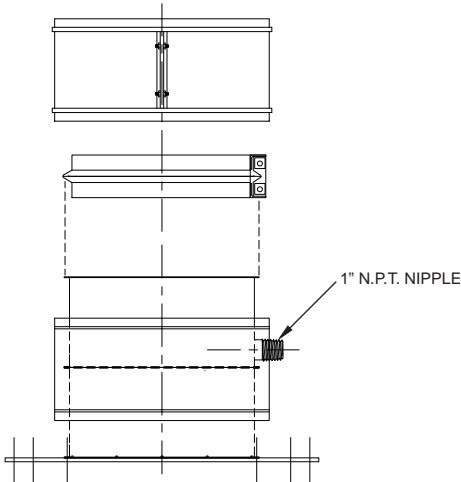


**DO NOT ATTACH THE FLOOR GUIDE TO COMBUSTIBLE CONSTRUCTION.**

### STACK SUPPORT ASSEMBLY (SSA)

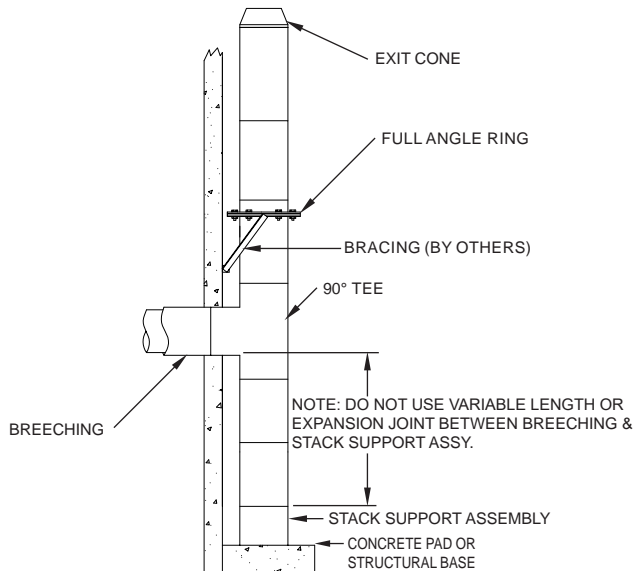
The stack support assembly is intended for use as a base mount for mounting the stack on a concrete floor or a structural steel stand. It is equipped with a predrilled steel baseplate for the insertion of anchor bolts or studs. A 9-inch section of pipe is attached to the baseplate and contains a false bottom 4½" (114) above the floor. A 1" (25) NPT nipple extends through the side of the pipe section just above the false bottom to allow drainage of rain or condensate (See FIG. 39). It is recommended that a 90° manifold tee with a cleanout cap be installed above the stack support to provide access to the stack.

FIG. 39 – STACK SUPPORT ASSEMBLY



When using a stack support assembly as the stack base, it is important to use exact pipe lengths to raise the stack height to the breaching connection point (See FIG. 40). Use of variable lengths or expansion joints in the stack under the breaching connection defeats the purpose of the stack support assembly. These components will not support weight.

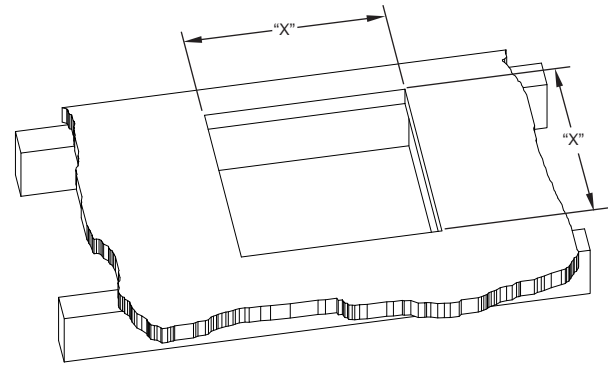
FIG. 40 – STACK SUPPORT ASSEMBLY INSTALLATION



### VENTILATED THIMBLE ASSEMBLY (VTA) AND ROOF SUPPORT ASSEMBLY (RSA)

The ventilated thimble assembly is designed to allow Model PIC/IPIC chimney to penetrate a combustible roof at a nominal 3" clearance to combustibles. FIG. 41 illustrates the required minimum framing dimensions. The ventilated thimble is intended for installation on a flat roof. It may be used on a pitched roof if a curb is installed at the penetration to provide a level surface for mounting the thimble.

FIG. 41 – ROOF FRAMING FOR VENTILATED THIMBLE ASSEMBLY OR ROOF SUPPORT ASSEMBLY

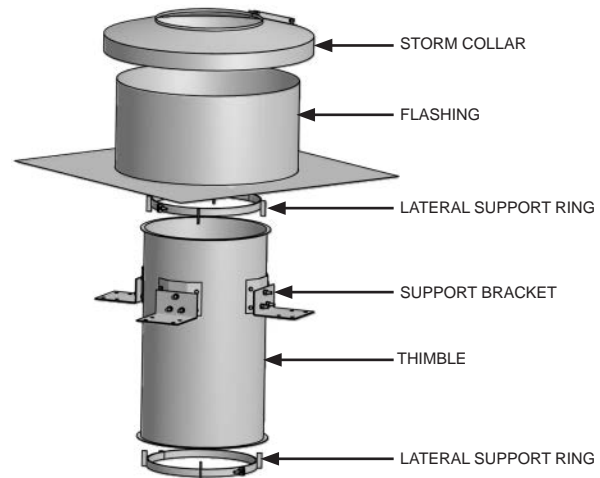


Model	PIC & IPIC-1	IPIC-2	IPIC-4
"X"	I.D. + 8" (203)	I.D. + 10" (254)	I.D. + 14" (356)

The roof support assembly is a special variation of the ventilated thimble which also provides vertical support to the chimney. It is especially useful when the chimney rise below the roof is long enough to cause movement from thermal expansion to exceed approximately 2" (51).

The ventilated thimble consists of the thimble with 4 support brackets; 2 lateral support rings, split for ease of installation; a flashing; a storm collar.

FIG. 42 - VENTILATED THIMBLE ASSY. INSTALLATION



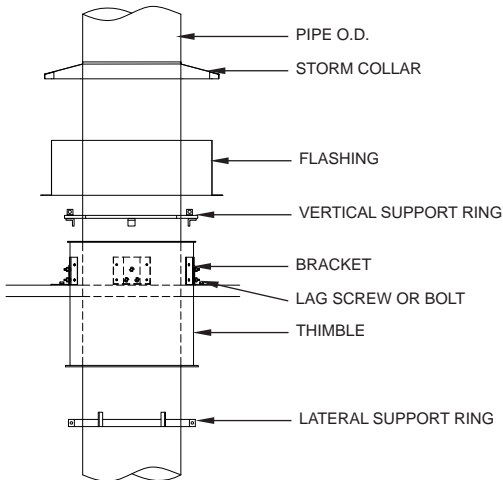
Installation of the ventilated thimble is as follows (See FIG. 42):

1. Cut the roof opening and reinforce the edges of the hole as appropriate for the expected load bearing requirements. Attach the thimble brackets to the thimble using the hardware provided.
2. Set the thimble through the roof, making sure it is centered in the roof penetration hole, and secure it to the roof deck with bolts or lag screws supplied. The brackets may be welded to a metal roof, if desired.
3. Install the chimney passing through the thimble and extending above the roof.
4. Install the 2 split lateral support rings on the chimney casing, one above the thimble and one below the thimble. Leave the bolts loose enough to allow the ring to slide along the casing. The spacer tabs are to be toward the thimble.
5. Push the lateral rings along the chimney casing until they are completely enclosed in the thimble.
6. Install the flashing centered on the thimble. Secure it to the roof and seal it to the roof membrane as appropriate.

7. Install the storm collar around the chimney casing allowing the ventilation spacers on the underside of the collar to rest on the upper edge of the flashing. Tighten the draw screw and seal between the collar and the chimney casing with chimney sealant.

The roof support assembly consists of the same parts as the ventilated thimble except that one of the lateral rings is replaced with a vertical support ring. Installation is identical to the ventilated thimble except step 4 (See FIG. 43).

**FIG. 43 - ROOF SUPPORT ASSY. INSTALLATION**

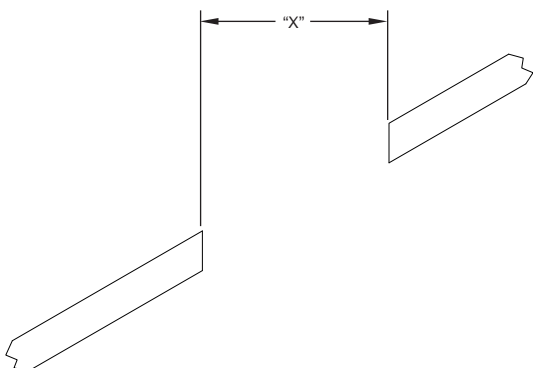


Install lateral support ring below thimble as per step 4 above. Then install the vertical support ring. Vertical ring consists of 2 half-clamp rings designed to lock together when assembled. The pipe section joint will rest on top of the assembled vertical support ring. The vertical support ring will rest on top of Thimble Flange and carries the weight of the chimney. Because it is not fastened to the thimble, the chimney can expand upward in the thimble if needed.

**FIXED PITCH VENTILATED THIMBLE ASSEMBLY (FPVTA) AND FIXED PITCH ROOF SUPPORT ASSEMBLY (FPRSA)**

These components are special variations of the ventilated thimble assembly. They provide the same clearance to combustibles and types of support, but are designed to be installed in pitched roofs. Installation is similar to the flat roof versions except for the following.

**FIG. 44 – ROOF FRAMING FOR VENTILATED THIMBLE ASSEMBLY OR ROOF SUPPORT ASSEMBLY**

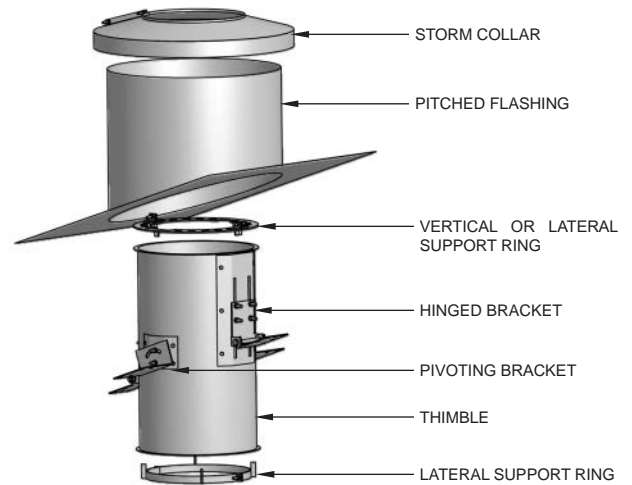


Model	PIC & IPIC-1	IPIC-2	IPIC-4
"X"	I.D. + 8" (203)	I.D. + 10" (254)	I.D. + 14" (356)

1. The roof opening is sized as a flat projection (See FIG. 44) to provide the correct clearance.
2. The thimble is centered in the roof hole with the two pivoting brackets oriented parallel to the roof ridge and the hinged brackets running up and down the roof. The brackets are secured to the roof with bolts, lag screws or welding as appropriate. Leave the bolts of the sliding mount loose until the brackets are attached to the roof. Then tighten all bolts and nuts.
3. Install the flashing centered on the thimble. Secure it to the roof and seal it to the roof membrane as appropriate.  
Note: The flashing pitch is fixed, specify required pitch rate with order.

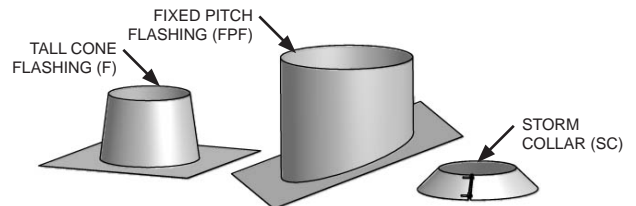
FIG. 45 illustrates details of the pitched roof penetration component installation.

**FIG. 45 – FIXED PITCH ROOF PENETRATION INSTALLATION**



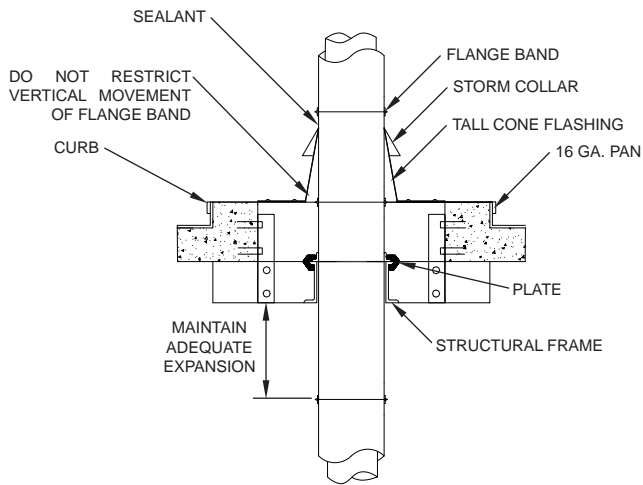
**FLASHING (F) FIXED PITCH FLASHING (FPF) AND STORM COLLAR (SC)**

Flashings, both standard (Tall Cone) and pitched, are intended for installation on non-combustible roofs only. The flashing is non-ventilated and does not provide for any reduced clearance to combustibles.



To install the flashing, place it around the chimney. Secure and seal it to the roof (FIG. 46).

**FIG. 46 – INSTALLATION OF FLASHING AND STORM COLLAR**



With the flashing in place, the storm collar is placed around the chimney and sealed to the casing with silicone sealer. The storm collar should not quite rest on the flashing when the chimney is cold ( $1/4$ " gap between the collar and the top of the flashing).

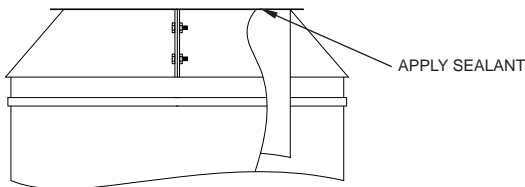
When a chimney is installed with a flashing and collar rather than a ventilated thimble, the chimney must be stabilized by installing either a full angle ring or a plate support just below the roof. If the chimney height above the plate support or full angle ring exceeds the "B" dimension in **TABLE 7 on PAGE 5**, it must be guyed to avoid wind damage.

**CHIMNEY TERMINATIONS**

**STACK CLOSURE RING (CR)**

The stack closure ring (**FIG. 47**) is the simplest method of terminating a chimney. It provides protection of the annular space between the inner and outer walls and leaves the top of the chimney open to the elements. A drain section (or tee with drain tee cap) should always be installed when a closure ring is used as a termination. The closure ring is installed on the inner wall and overlaps the outer wall. The joint at the inner wall should be sealed with chimney sealant. A closure ring may be used for either vertical or horizontal discharge.

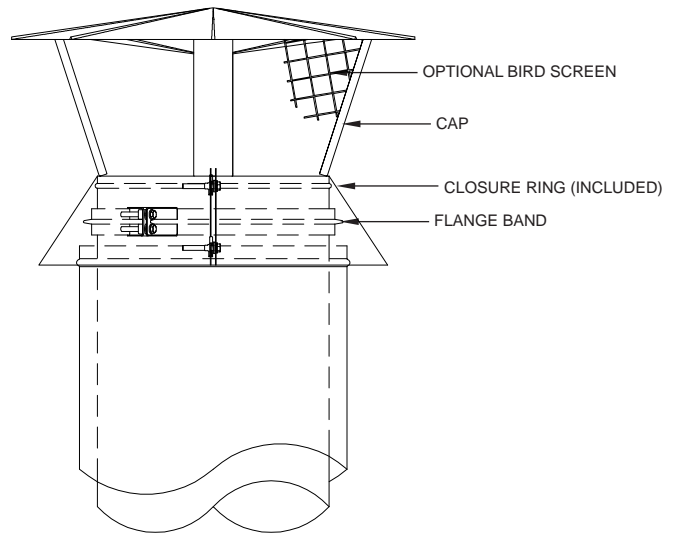
**FIG. 47 – STACK CLOSURE RING**



**STACK CAP (C)**

The stack cap (**FIG. 48**) is designed to offer partial protection from rain entering the chimney. It is equipped with an inverted cone to divert flue gases upward to avoid contamination of the surrounding roof area. The cap may be equipped with a birdscreen if desired. The stack cap is intended for use as a termination only for a vertical discharge.

**FIG. 48 - STACK CAP**

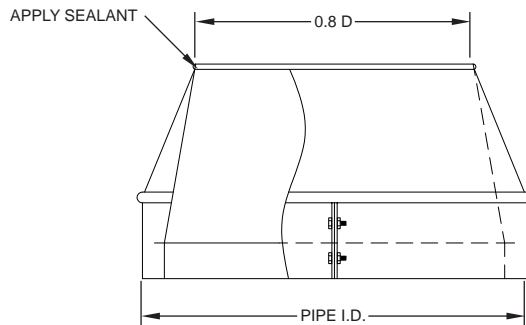


A cap is attached to the top section of pipe with a flange band and sealant. The annular opening between the inner and outer walls of the pipe is protected with a closure ring provided with the cap. When the chimney is terminated with a stack cap, it is recommended that provisions be made for drainage of rain from the base of the stack.

**EXIT CONE (EC)**

The exit cone (**FIG. 49**) is designed to produce additional gas velocity at the chimney exit to help disperse the effluent. The opening of the cone is based on a ratio of 0.8 times the nominal pipe diameter. Since the exit cone is an open top termination, provision for drainage is recommended. An exit cone may be used for either vertical or horizontal discharge.

**FIG. 49 – EXIT CONE**



**STACK HEAD ASSEMBLY (SHA)**

The stack head assembly is designed for free, unobstructed venting of the chimney while providing maximal protection from rain entering the chimney. The stack head is a "low loss" termination and is recommended by the Industrial Ventilation Manual, 20<sup>th</sup> Edition, American Conference of Industrial Hygienists, FIG. 8-6.

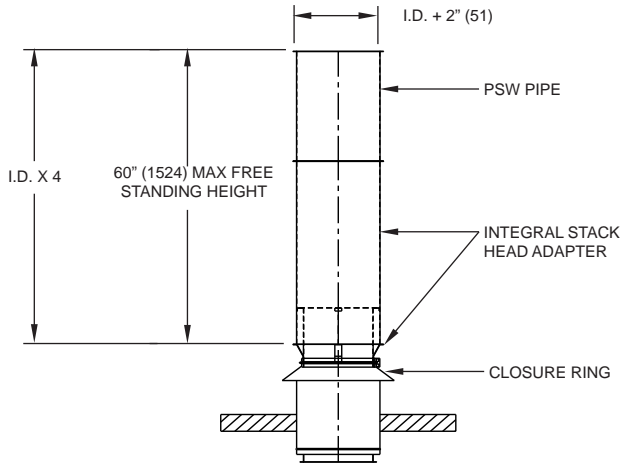
For diameters 6" – 24", the stack head adapter section is an integral component that attaches to the chimney flue using a flange band and sealant. PSW sections are added to the desired height. A closure ring is attached to the flue to protect the annular space between the inner and outer walls from rain (See **FIG. 50A**). The maximum free standing height of the stack head assembly is 60" (1524). Heights above 60" (1524) will require guying.



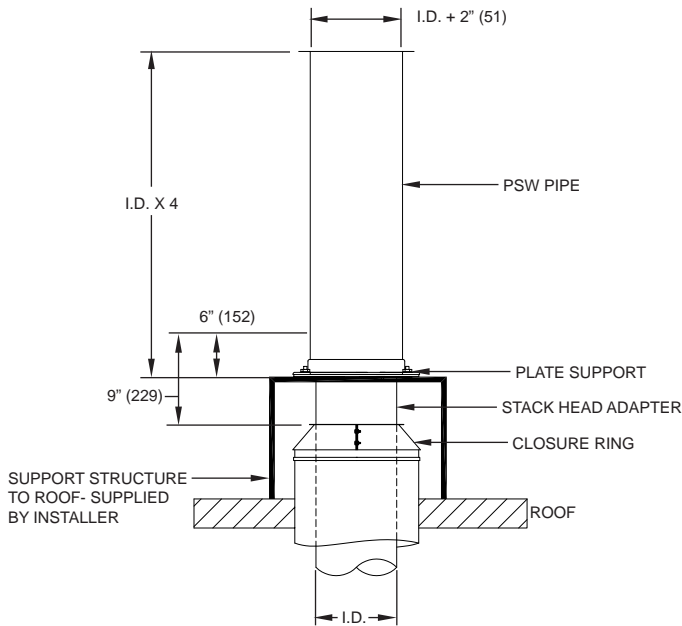
For diameters 26" thru 48" the chimney flue is terminated 9" (229) below the required height for the installation (consult local codes). A stack head adapter section is attached to the top section of the chimney using a flange band and sealant. A closure ring is attached to the flue to protect the annular space between the inner and outer walls from rain. A plate support is located 6" (152) below the top of the stack head adapter and PSW (Single Wall) pipe, one size larger than the nominal chimney size, is attached to it. The PSW pipe is equal in height to 4 times the chimney diameter (See FIG. 50B). For guying requirements see TABLE 7 on Page 5.

**Note:** The structural steel supports for the stackhead are provided by the installer. The stackhead assembly is intended for use as a termination only for vertical discharge.

**FIG. 50A – STACK HEAD ASSEMBLY**



**FIG. 50B – STACK HEAD ASSEMBLY**

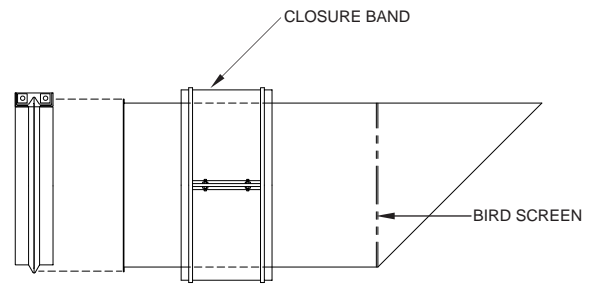


**MITER CUT (MC)**

The miter cut is intended for use as a termination for a horizontal discharge. It is designed to minimize the entry of rainwater when installed in the proper orientation. Note that the miter cut is a single wall part and requires a clearance of 18" (457) to combustibles.

The miter cut is equipped with a birdscreen at the short side of the miter (See FIG. 51). The miter must be installed so that the long side of miter is on the top of the pipe to afford protection from rain.

**FIG. 51 - MITER CUT (MC)**

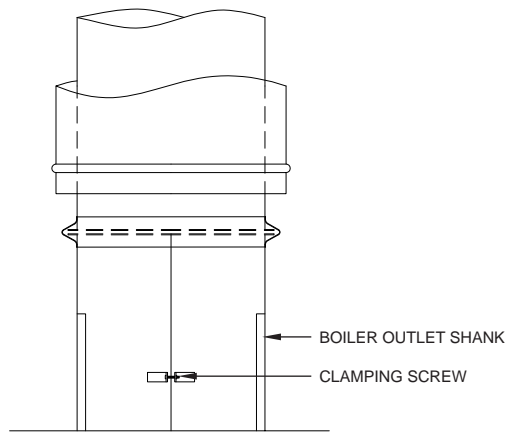


**APPLIANCE CONNECTORS**

**SINGLE WALL BOILER ADAPTER (SBA)**

The single wall boiler adapter is the most commonly used appliance connector. It is designed to clamp over a shank type flue gas outlet. A thin layer of sealant, about 1" (25) wide is spread on the end of the appliance outlet shank. Then the single wall boiler adapter is placed around the shank covering the sealant. The draw screw on the split tube is tightened to hold the single wall boiler adapter in place (See FIG. 52).

**FIG. 52 – SINGLE WALL BOILER ADAPTER**

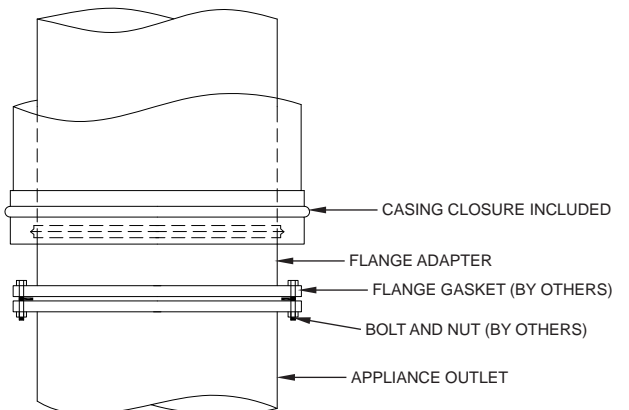


The single wall boiler adapter is 6" (152) long. A 4" (102) long variation is available on request.

**FLANGE ADAPTER (FA)**

The flange adapter is intended for use as a connection to a Class 125 or 150 ANSI pipe flange. This type of connection requires a flange gasket and bolt set supplied by the installer. The gasket and bolts are typically sold by pipe, valve and fittings houses as an "NBG" set. FIG. 53 illustrates a typical installation.

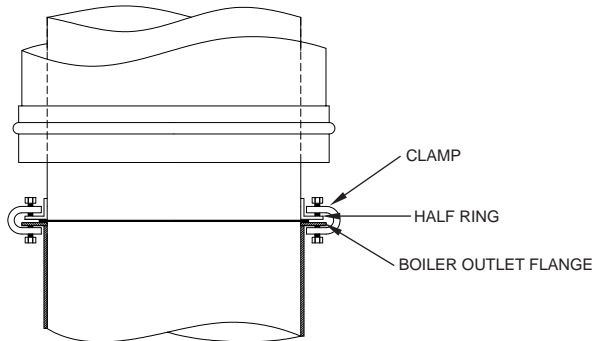
**FIG. 53 – FLANGE ADAPTER**



## BOILER FLANGE ADAPTER (BFA)

The boiler flange adapter is used to connect PIC/IPIC pipe to flanged appliance outlets other than those with ANSI pipe flanges. Typical use includes boilers, water heaters and connection to existing fabricated pipe. The adapter is designed to sandwich the 1/2" inner pipe flange between the appliance outlet and the boiler flange adapter (See FIG. 54). The boiler flange adapter is shipped with beam clips used to clamp the BFA to the appliance flange. The connection may also be drilled and bolted or welded if desired.

FIG. 54 - BOILER FLANGE ADAPTER INSTALLATION



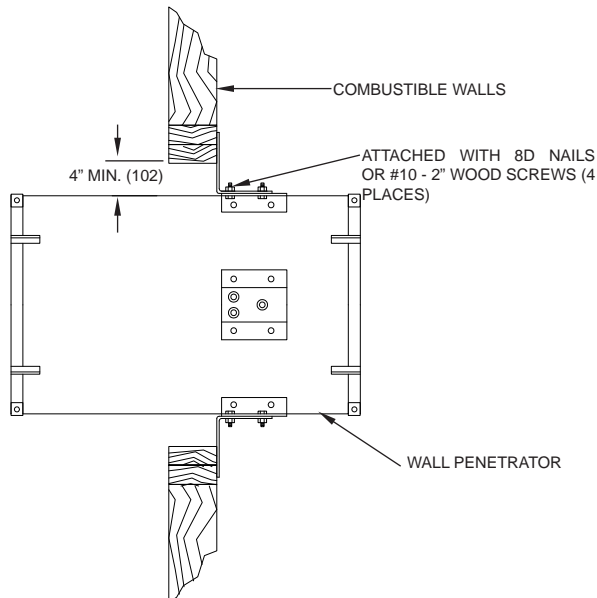
## WALL PENETRATOR (WP)

This part is used to allow PIC/IPIC pipe to pass through non-fire rated walls at reduced clearance. It consists of a 30" (762) long thimble with mounting brackets. The wall penetrator is mounted as follows:

1. Cut the opening in the wall. See chart below for opening size.
2. Position the wall penetrator tube in the opening so it is centered. Secure it to the wall with bolts or lag screws (supplied.)
3. Install pipe so that it passes through the center of the wall penetrator. Install lateral braces around the pipe casing. Leave rings loose enough to slide along pipe.
4. Push the lateral rings into the wall penetrator centering the tabs within the ends of the tube.

Model	PIC & IPIC-1	IPIC-2	IPIC-4
"X"	I.D. + 8" (203)	I.D. + 10" (254)	I.D. + 14" (356)

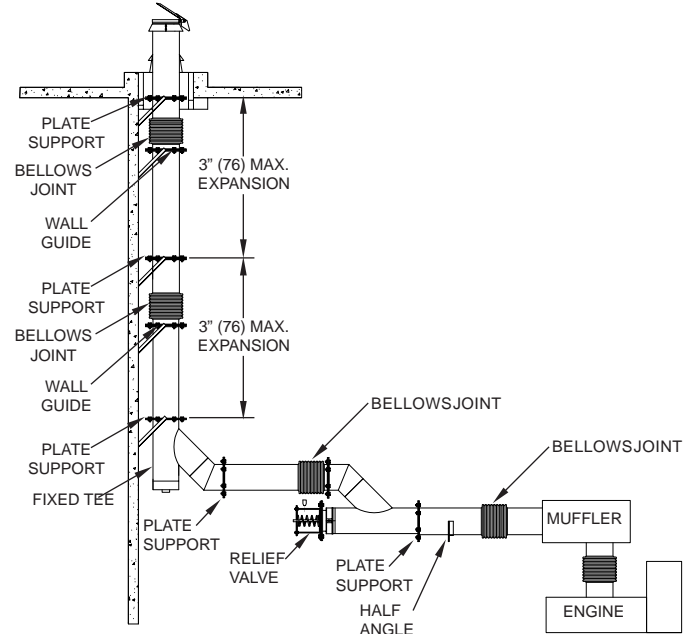
FIG. 55 - WALL PENETRATOR (WP)



## ENGINE EXHAUST SYSTEM PRECAUTIONS

Engine exhaust systems require extra attention to support and protection detail due to the possibility of delayed fuel ignition in the exhaust system. It is important that all turns are protected as illustrated in FIG. 14, 16 & 18 or rigidly attached to structural framing or walls. FIG. 56 illustrates some of the special considerations that must be considered when designing an engine exhaust system.

FIG. 56 – ENGINE EXHAUST CONSIDERATIONS



**IMPORTANT:** When installed vertically, bellows joint must not support weight of stack. Locate bellows joint near the lower side of fixed support as shown in FIG. 55.

The following components are primarily for use on engine or turbine exhaust systems.

## BELLOWS JOINT (BJ)

**Note:** Standard bellows joints require greater clearance to combustibles that double wall components. See Table 9 for standard single wall and optional double wall bellows joints for clearances.

Bellows joints are recommended for vibration and expansion movement. This type of movement is typically encountered in diesel engine or turbine exhaust applications. FIG. 56 illustrates typical bellows joint locations in a diesel engine exhaust system.

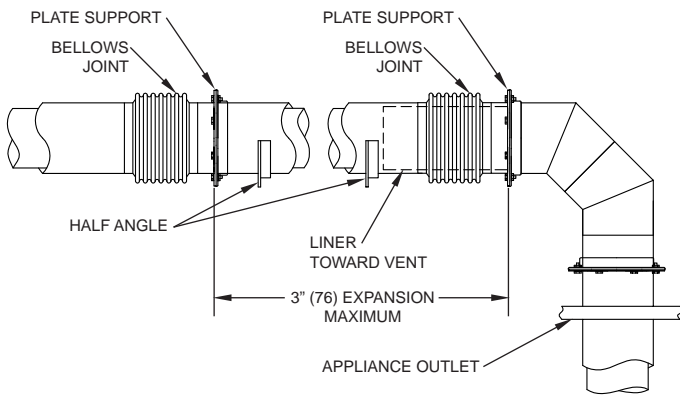
**NOTE:** Bellows Joints are required for expansion joints in high pressure applications including engine or turbine exhaust. Systems that use Bellows Joints are to use seal clips (See TABLE 4 on Page 5) and additional joint sealant per Page 23.

**TABLE 9 - BELLOWS JOINT CLEARANCE**

Location	Size	Single Wall	Double Wall
<b>Exterior</b>	Combustible	6" - 48"	18"
	Non-combustible	6" - 18"	2"
		20" - 48"	4"
<b>Interior</b>	Combustible	6" - 48"	18"
	Non-combustible	6" - 18"	2"
		20" - 48"	4"

**NOTE: P071 Sealant must be used for all joint connections when Bellows Joints are required. For exterior installations, sealant must be cured before exposure to moisture.**

**FIG. 57 – BELLOWS JOINT LOCATION IN DIESEL ENGINE EXHAUST SYSTEM**



Bellows joints may be used in either horizontal or vertical positions. It is imperative that the bellows joint be properly supported and guided in either orientation. A bellows joint is typically supported by a plate or wall support assembly on the appliance end of the bellows and guided by a full angle ring or wall guide on the exhaust end. The exhaust side guide should be located approximately 6"-12" (152-305) from the downstream end of the bellows joint.

**IMPORTANT: When supporting high rise exhaust systems, bellows joints must be located just below every fixed support to prevent compression at ambient temperatures (See FIG. 57).**

Good design indicates that any section of exhaust piping over 4' (1.2m) between fixed points be equipped with a bellows joint. A bellows joint can compensate for up to 3" (76) of expansion. The entire exhaust system should be examined to assure that bellows joints are installed in pipe runs in which 3" (76) or less of expansion is expected. For a method of calculating expansion (See **NOTE 3 on PAGE 11** under expansion joints).

For example, a 60-foot run (18.3m) of exhaust pipe handling 1000° F flue gas would produce  $60\text{ft}/100 \times 1000^\circ\text{F}/100 = 6"$  (152) of expansion. This run would require 2 bellows joints.

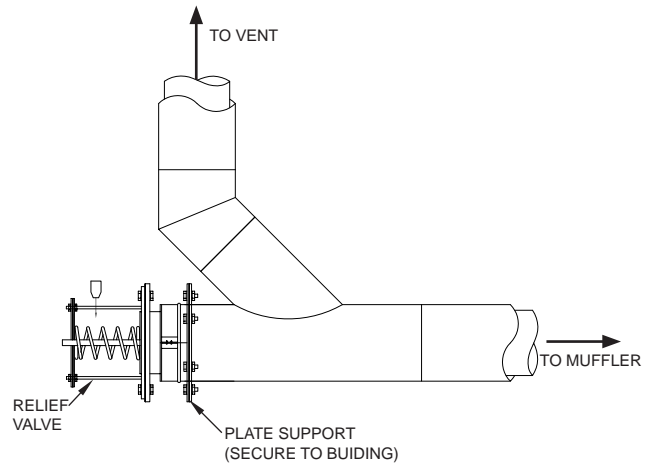
The bellows joint is lined to minimize contact between the bellows and exhaust gases. Thus, it cannot be used to correct mis-alignment. The liner extends approximately 2" (51) past one end of the bellows joint flange. This extension should always be toward the downstream (exhaust) side of the system to avoid becoming an obstruction for the shockwave in the event of a delayed ignition incident in the exhaust system.

**RELIEF VALVE (RV)**

The relief valve is intended for use with diesel engines to provide extra protection to the pipe in case of a delayed ignition of unburned fuel in the exhaust system. It consists of a spring loaded disk valve mounted on a flange adapter. The valve is factory calibrated to open at 27 in. wc. The calibration nuts must not be changed or the valve may not function correctly.

The relief valve must be supported independently of the rest of the exhaust system. The best method to accomplish this is to locate a plate support at the joint between the relief valve and the adjacent fitting. It is crucial that the plate support be properly secured to building structure so that it can withstand the forces generated in case of delayed fuel ignition (See **FIG. 58**).

**FIG. 58 – RELIEF VALVE SUPPORT (RV)**

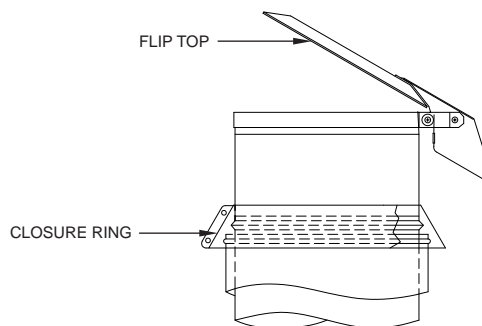


**METAL-FAB RECOMMENDS THAT ALL DIESEL ENGINE EXHAUST SYSTEMS BE EQUIPPED WITH RELIEF VALVE.**

**FLIP TOP (FT)**

The flip top (**FIG. 59**) is designed to be installed either on a vertical or horizontal exhaust. If installed on a horizontal termination, the hinged side of the top must be oriented at the top of the pipe keeping the counterweight up.

**FIG. 59 – FLIP TOP (FT)**



**USE OF VARIABLE LENGTH**

Metal-Fab generally recommends the use of fixed custom lengths where standard lengths do not work for engine exhaust systems (See Pages 10 and 11). If a variable length must be used, the inner tube must be installed with the flanged end toward the engine. This allows an unobstructed flow path in case of a delayed ignition occurrence.

**THE INFORMATION ON THIS PAGE PERTAINS TO ALL APPLICATIONS**

<b>TABLE 3 - EXPECTED NUMBER OF TUBES PER JOINT</b>					
<b>(P071 OR P077 SEALANT)</b>					
<b>Pipe Diameter</b>	<b>No. of Tubes</b>	<b>Pipe Diameter</b>	<b>No. of Tubes</b>	<b>Pipe Diameter</b>	<b>No. of Tubes</b>
6"	0.20	22"	0.33	38"	1.00
8"	0.20	24"	0.50	40"	1.00
10"	0.20	26"	0.50	42"	1.00
12"	0.25	28"	0.50	44"	1.00
14"	0.25	30"	0.67	46"	1.20
16"	0.25	32"	0.67	48"	1.20
18"	0.33	34"	0.67		
20"	0.33	36"	0.67		

<b>EXPECTED NUMBER OF TUBES PER JOINT FOR PRESSURE SEALS, IN ADDITION TO THE ABOVE</b>					
<b>(P071 SEALANT)</b>					
<b>Pipe Diameter</b>	<b>No. of Tubes</b>	<b>Pipe Diameter</b>	<b>No. of Tubes</b>	<b>Pipe Diameter</b>	<b>No. of Tubes</b>
6"	0.60	22"	1.80	38"	3.60
8"	0.70	24"	2.10	40"	3.70
10"	0.90	26"	2.20	42"	3.80
12"	1.00	28"	2.40	44"	4.10
14"	1.10	30"	2.67	46"	4.30
16"	1.33	32"	2.90	48"	4.50
18"	1.55	34"	3.00		
20"	1.67	36"	3.20		







An OLYMPIC **STEEL** Company

P.O. Box 1138 • WICHITA, KANSAS 67201  
(316) 943-2351 • FAX (316) 943-2717  
info@metal-fabinc.com • www.metal-fabinc.com